

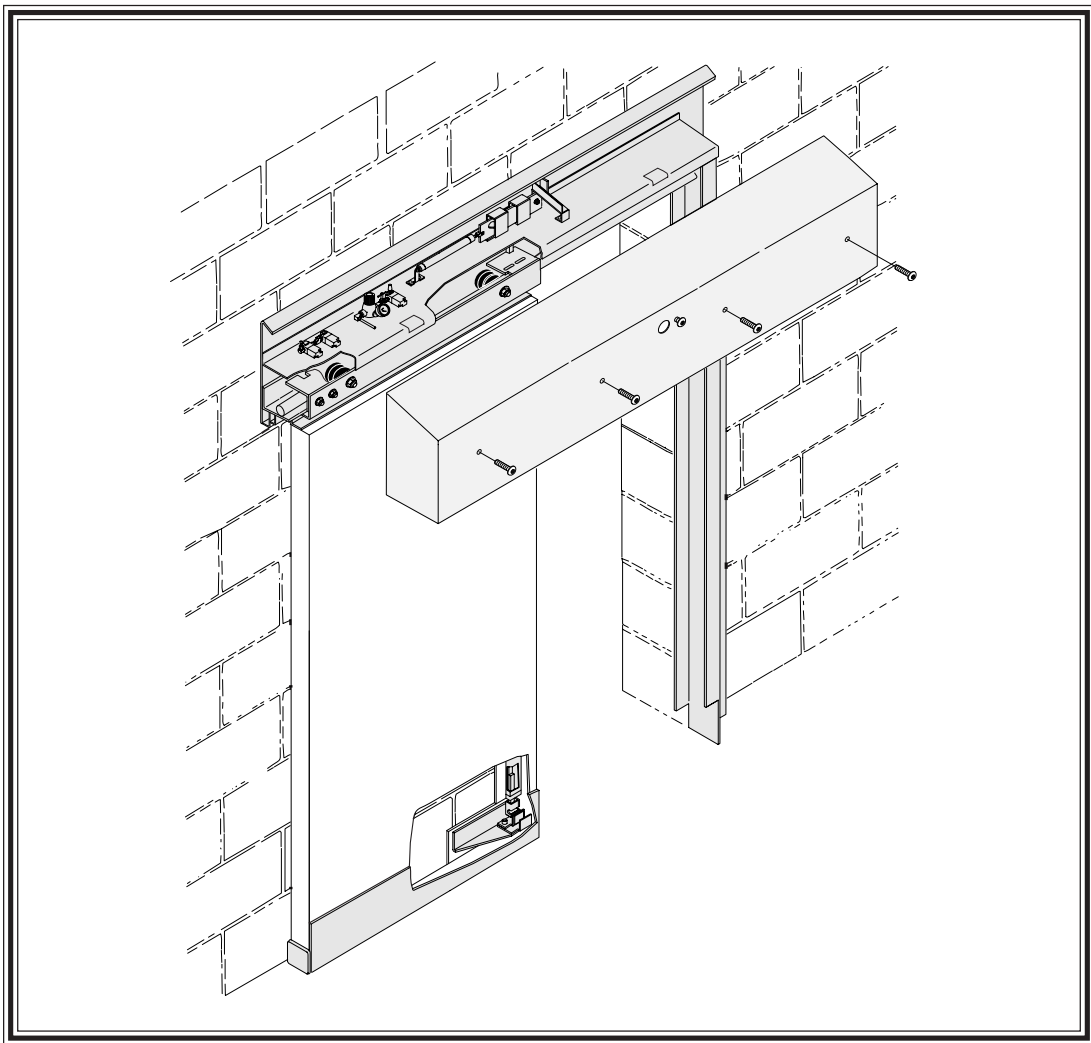

## 8210 SERIES SLIDING DOOR OPERATOR

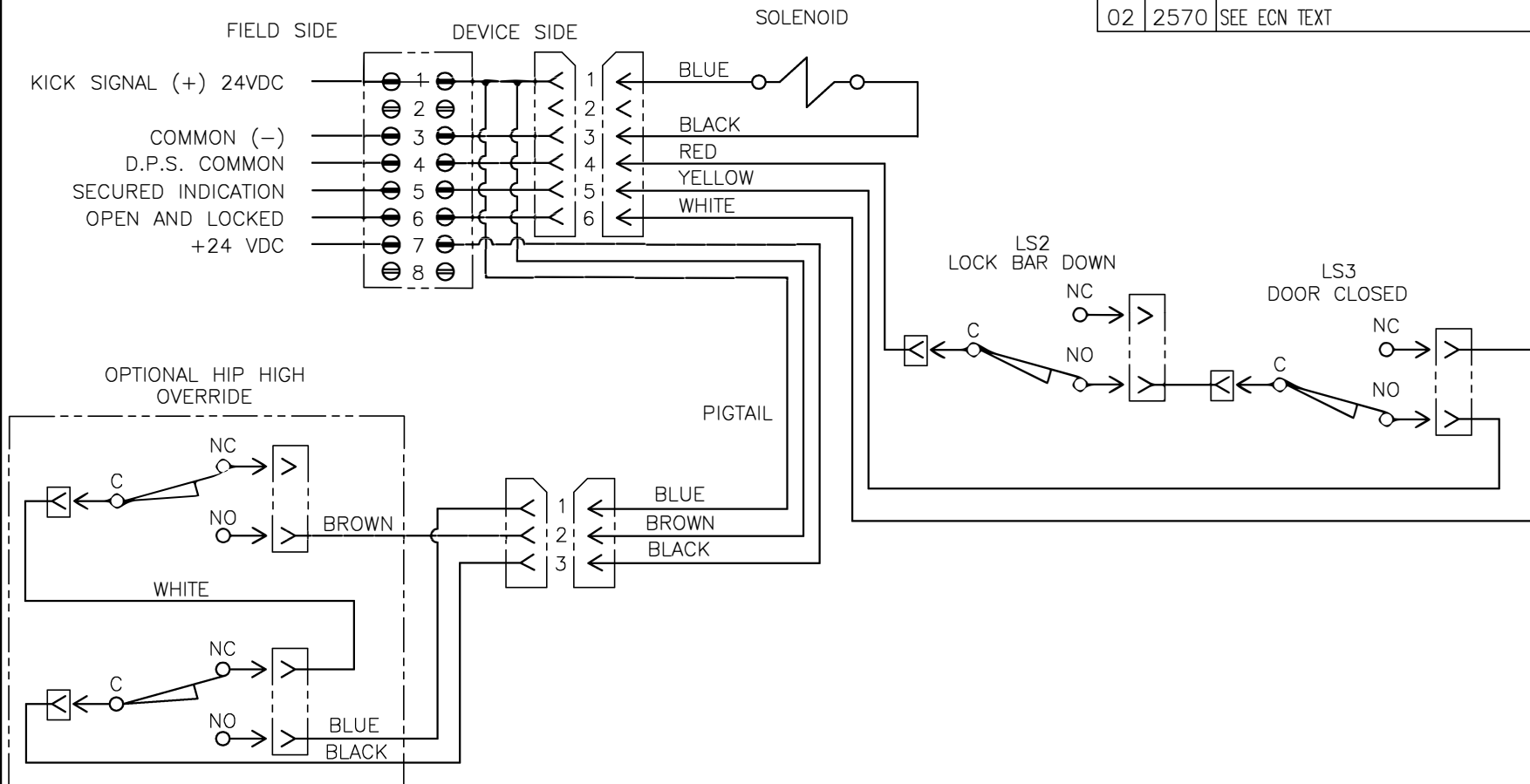

REVISIONS				
REV	ECN	DESCRIPTION	DRN	CHK
01	2034	TITLE WAS WIRING DIAGRAM, 8210 SERIES SLIDERS	KEK 3/12/97	
02	2570	SEE ECN TEXT	DEE 2/5/03	



NOTES:  
 1. SCHEMATIC SHOWN WITH DOOR IN THE CLOSED AND LOCKED POSITION.  
 2. SOLENOIDS 2.4 WATTS.  
 3. ALWAYS INSTALL IN ACCORDANCE WITH LOCAL REGULATIONS AND THE NATIONAL ELECTRIC CODE (NEC). POWER DEVICE FROM A CLASS 2 POWER SOURCE WHEN PNEUMATIC TUBING OCCUPIES THE SAME SPACE AS CONTROL WIRING.



TITLE		DRAWN BY DKM	
WIRING DIAGRAM, 8210 & 8215 SERIES SLIDERS		APPROVED	
		DATE 11-8-94	
		SCALE NONE	
© 1989 AIRTEQ SYSTEMS.	SIZE B	DWG. NO. EL-0038-B	REV 02

REVISIONS				
REV	ECN	DESCRIPTION	DRN	CHK

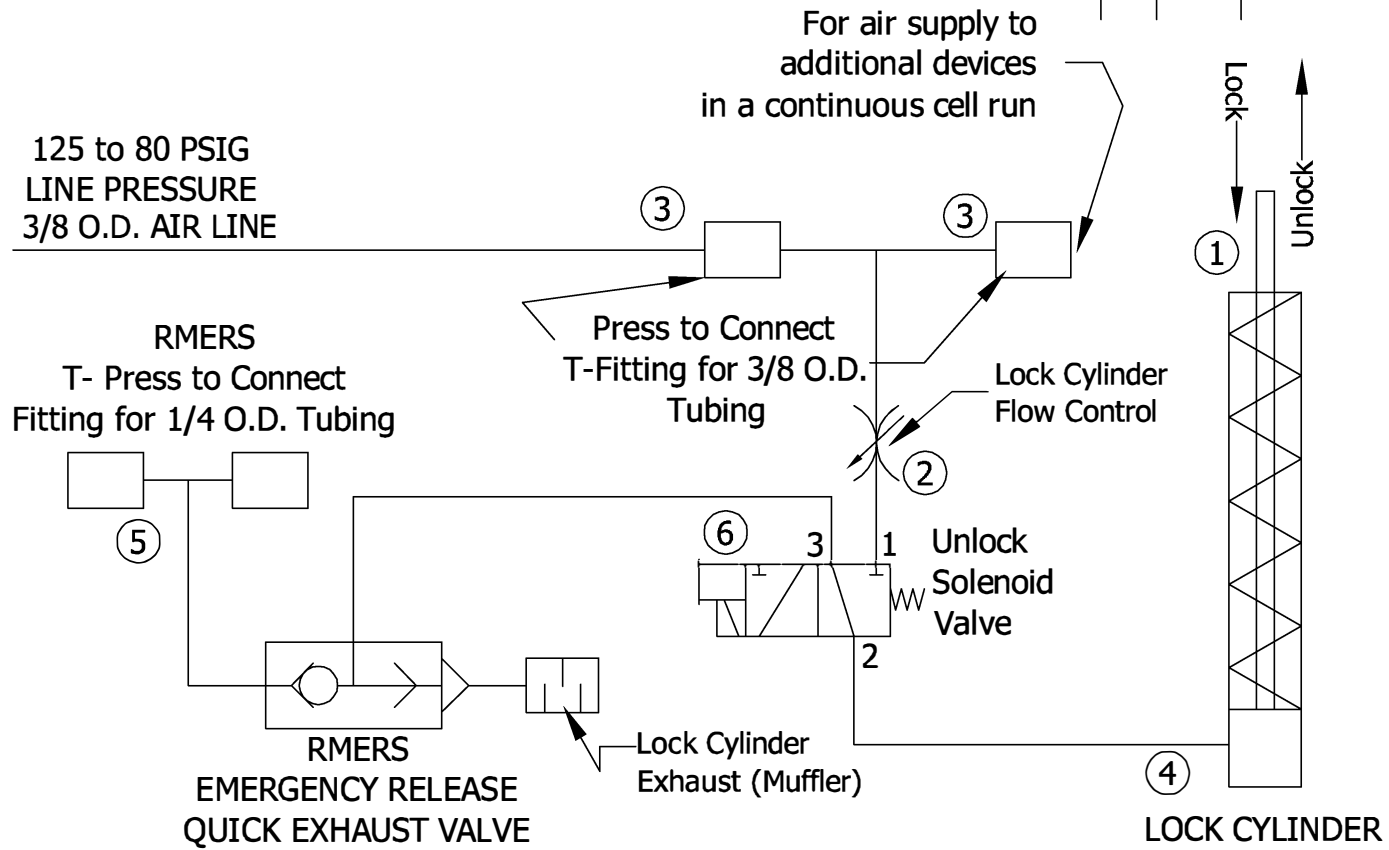

NOTES:

1. SCHEMATIC SHOWN WITH DOOR IN THE CLOSED AND LOCKED POSITION
2. EXTRA FINE THREAD SCREW ADJUSTMENT REQUIRED FOR FLOW CONTROL
3. MAIN AIR SUPPLY IS 3/8"OD x .25"ID BLACK NYLON 11 TUBE.
4. ALL INTERNAL PLUMBING IN .25"OD x .17"ID BLACK NYLON 11 TUBE.
5. EMERGENCY AIR SUPPLY (OPTIONAL) IN .25"ID x .17"ID RED NYLON 11 TUBE.
6. VALVE SPECIFICATIONS:  
UNIVERSAL 3 WAY INLINE, 0.08CV; SOLENOID 24VAC, 2.4W
7. REFER TO DRAWING NO. 820832 FOR ELECTRICAL SCHEMATIC



TITLE		DRAWN BY RLP	
AIR SCHEMATIC, 8210 & 8215 SERIES SLIDERS		APPROVED	
		DATE 4/18/08	
© 1989 AIRTEQ SYSTEMS.		SCALE NONE	REV
SIZE B	DWG. NO. PN-0011-B		

**8210 SERIES SLIDING DOOR  
PARTS LIST**

ITEM	QTY	PART NUMBER	DESCRIPTION	ITEM	QTY	PART NUMBER	DESCRIPTION
1	1	**	BACKPLATE WELDMENT, L/C (SHOWN)	39	4	10001410	LOCK WASHER, 1/2
1	1	**	(OR) BACKPLATE WELDMENT, R/C	40	4	10000710	FLAT WASHER, 1/2
2	1	82008901	ASSY, LIMIT SWITCH, LH (SHOWN)	41	4	10000210	HEX NUT, 1/2-13
2	1	82008902	(OR) ASSY, LIMIT SWITCH, RH	42	2	820501	ASSY, KICK RELEASE
3	6	10001301	SCREW, CARRIAGE, 1/4-20 X 3/4	43	2	10001001	SCREW, HEX, CAP, 3/8-16 X 5/8, GRD 5
4	1	821016	ASSY, INSIDE GUIDE	44	1	820073	SHUTTER
5	4	10006209	SELF RETAINING NUT, SHORT, 3/8-16	45	6	10001006	SCREW, HEX, CAP, 3/8-16 X 1
6	11	10002407	NYLOCK NUT, 1/4-20 ZINC PLATED	46	1	**	DOOR SKIRT
7	1	821017	ASSY, OUTSIDE GUIDE	47	AS REQD	10003402	SCREW, TP, BH, 10-32 X 1/2
8	11	10000706	FLAT WASHER, 1/4 TYPE 'B' REG	48	1	**	LOCKBAR WELDMENT
9	1	820085	OVERRIDE GUIDE L/C (SHOWN)	49	1	**	LOCKTUBE WELDMENT
9	1	820225	(OR) OVERRIDE GUIDE, R/C	50	1	820170	DOOR GUIDE BRACKET, L/C (SHOWN)
10	1	82004102	ASSY, VALVE, KR	50	1	820181	(OR) DOOR GUIDE BRACKET, R/C
11	2	10002402	HEX NUT, SEMS, 6-32	51	1	**	JAMB, CHANNEL, L/C (SHOWN)
12	2	10002303	SCREW, RH, SLOTTED, 6-32 X 1	51	1	**	(OR) JAMB, CHANNEL, R/C
13	1	82004301	ASSY, LOCK CYLINDER, L/C (SHOWN)	52	1	820072	DOOR STOP PLATE
13	1	82004302	(OR) ASSY, LOCK CYLINDER, R/C	53	1	**	DOOR GUIDE, L/C (SHOWN)
14	1	82008705	ASSY, LOCK SWITCH, L/C (SHOWN)	53	1	**	(OR) DOOR GUIDE, R/C
14	1	82008706	(OR) ASSY, LOCK SWITCH, R/C	54	1	**	8200 SERIES WIRING HARNESS (NOT SHOWN)
15	5	10003401	SCREW, TP, BH, 3/8-16 X 1	55	4	10006008	SPACER
16	1	10002802	WASHER, CONICAL SERRATED, 3/8	56	4	10001002	SCREW, HEX, CAP, 3/8-16 X 1-1/4
17	1	820021	LOCKBAR SLIDE BRACKET				
18	1	820223	OVERRIDE CATCH, L/C (SHOWN)				
18	1	820080	(OR) OVERRIDE CATCH, R/C				
19	1	10000101	PEM STUD, 1/4-20 X 3/4				
20	1	100072	TERMINAL STRIP				
21	2	10001000	SCREW, HEX HD, 6-20 X 1/2 TYPE 'AB'				
22	1	820107	LOCKBAR SLIDE BEARING				
23	1	10002503	SHOULDER SCREW, 3/8 X 1-1/2 LG, 5/16-18				
24	1	82019401	LOCK BRACKET, REAR, L/C (SHOWN)				
24	1	82019201	(OR) LOCK BRACKET, REAR, R/C				
25	2*	10000707	FLAT WASHER, 5/16, TYPE 'B' REG				
26	2*	10001004	SCREW, HHCS, 5/16-18 X 1-1/2, W/NYLON PATCH, GRD 8				
27	10	10000708	FLAT WASHER, 3/8, TYPE B, REG.				
28	10	10001408	LOCK WASHER, 3/8				
29	6	2NT61	HEX NUT, 3/8-16				
30	1	**	DOOR HANGER				
31	1	**	HOUSING COVER, L/C (SHOWN)				
31	1	**	(OR) HOUSING COVER, R/C				
32	4	10001302	SCREW, CARRIAGE, 1/2-13 X 1-1/4				
33	2	82009801	ASSY, ROLLER				
34	1	820195	LOCK BRACKET, FRONT, L/C (SHOWN)				
34	1	820193	(OR) LOCK BRACKET, FRONT, R/C				
35	1	820366	PUSH BRACKET, K-R				
36	1	**	SWITCH ACTUATOR BRACKET				
37	2*	10002803	WASHER, CONICAL, SERRATED, 5/8				
38	2*	10000211	HEX NUT, 5/8-11				

\* PART OF ASSY, ROLLER ITEM #33  
\*\* PART NUMBER ASSIGNED ON A JOB BY JOB BASIS.

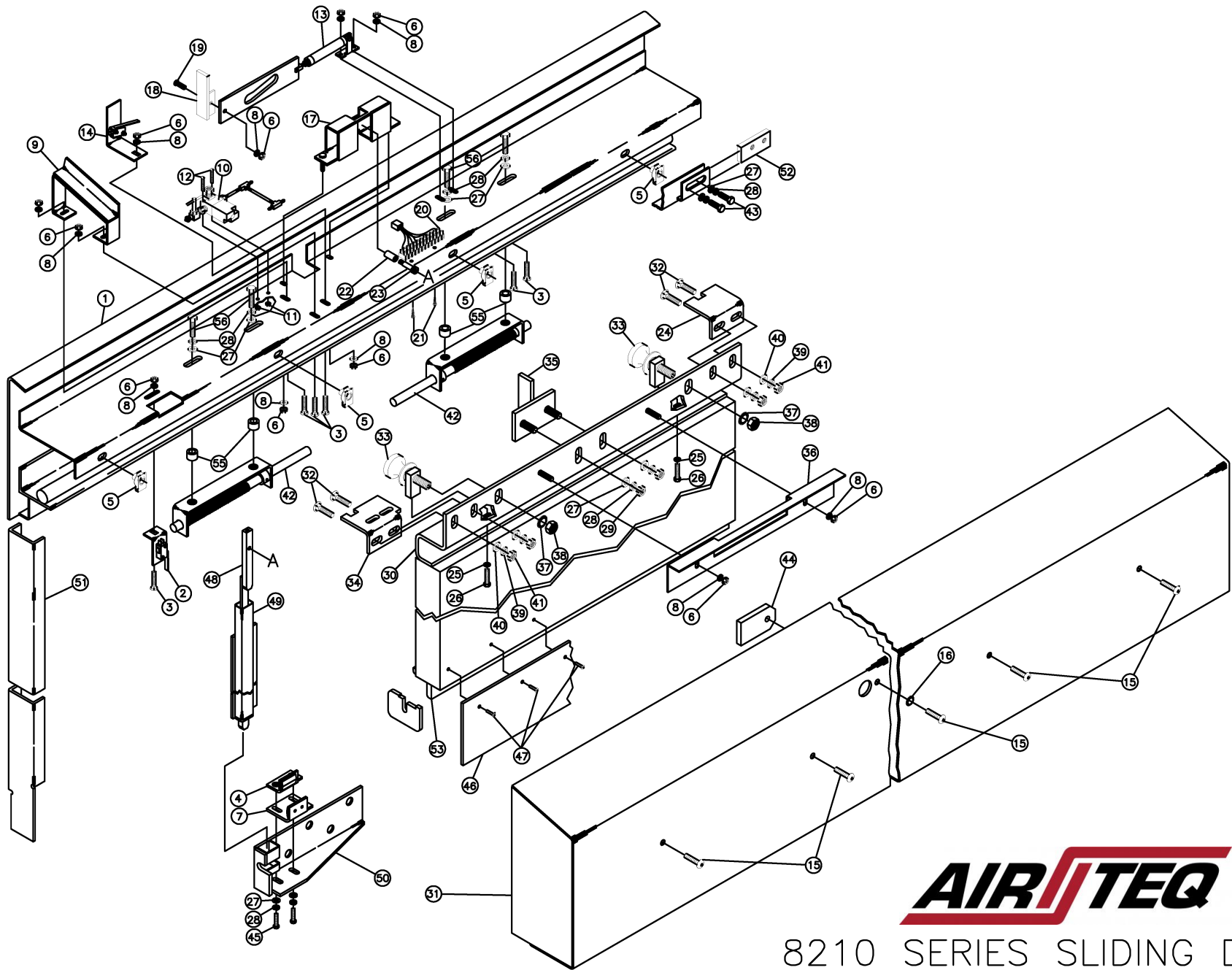

**AIR/TEQ**

8210 SERIES SLIDING DOOR

# MAINTENANCE

The Airteq 8210 & 8215 Series Pneumatic Door operators require a minimum amount of maintenance. It is recommended that the following items be checked once every six months.

## 1) Lubrication (Fig. A)

The lock mechanism and rack should be well lubricated with Super Lube Multi-Purpose Synthetic Lubricant (either spray or grease) OR equivalent. Check to see that the grease has not dried, caked, or become contaminated with dust or other debris. If the grease is not in good condition, wipe as much as possible from the lock mechanism and rack and apply new grease. This also applies to the lock motor linkage, bellcrank, manual override mechanism and kick release bracket.

The kick and lock cylinder piston rods should be wiped clean and relubricated. DO NOT use any solvents or penetrating oils on the cylinder rod. Wipe the old lubricant off with a lint free cloth. Coat the cylinder rod with a thin film of Parker Luba-A-Cyl, Part #0761630000. DO NOT use WD 40 or similar products as they will cause cylinder seal failure.

NOTE: Bellcrank and manual override mechanism are not present on the 8210 model.

## 2) Bottom Guide Wear Pads (Fig. D)

The bottom of the door is held in place with two nylon wear pads. These may wear with use. Check to see that there is not excessive door movement in and out from the wall. One sixteenth of an inch movement at the bottom of the door is acceptable. If there is more play than this, the guides need to be adjusted or replaced.

To adjust the bottom guide, slightly loosen the two bolts on the bottom side of the bottom guide mounting bracket. Loosen the bolts just enough to squeeze the guides tighter to the door guide angle. Be sure to leave enough clearance to allow for smooth operation.

### **3) Roller Track**

Do not lubricate the roller track.

To maintain smooth and quiet operation, the roller track must be kept free of any accumulation of dirt, dust, or other debris. If the track does not feel smooth, wipe it off with a lint free cloth or scouring pad. Do not use steel wool, sandpaper, or anything that may leave grit or fibers on the track.

### **4) Rollers**

The roller assemblies are factory lubricated and sealed. They do not require lubrication. If the track is clean and the rollers still do not roll smoothly, wipe the rollers with a clean lint-free cloth.

# MECHANICAL ADJUSTMENTS

## 1) Lock Position (Fig. C)

The lockbar engages the door at the top and bottom in both the open and closed positions. The top locking points are adjustable.

While holding the door tight against the receiver column, manually raise and lower the lockbar. This can be done by moving the horizontal lock slide by hand.

If the lockbar contacts the rear lock bracket, the bracket should be adjusted. Loosen the two nuts securing the bracket to the door hanger. Move the bracket as needed to obtain clearance on both sides of the lockbar. Before tightening the nuts, make sure the lock bracket is level and that the lockbar extends 1/8" below the lock bracket. Tighten the nuts securely.

To check and/or adjust the front lock bracket, repeat the above procedure with the door in the fully open position.

## 2) Door Height (Fig. D & Fig. E)

Improper door height may result in the door hanger rubbing on the cover, or the bottom door guide angle rubbing on the top or bottom of the locktube notch.

There are two height adjustment bolts, one for each side of the door. One complete turn will move the door up or down 1/16". Turn the bolt clockwise to raise the door and counterclockwise to lower the door. When making height adjustments, first determine how much change is needed, loosen the axle nut, turn the adjustment bolt the appropriate amount, then tighten the axle nut securely and check for proper clearances.



### **3) Lateral Door Position (Fig. D & Fig. E)**

The sliding door should clear the lock tube and the sides of the receiving pocket by approximately 1/16". If the door rubs on any of these surfaces, or if the door hanger rubs on the cover, adjustment is required.

#### **a) Top Of Door (Fig. E)**

The top of the door can be adjusted at both the front and rear edge of the door.

Loosen the appropriate axle nut. While holding the nut with the wrench, turn the axle with a 1/4" Allen wrench. Each complete turn of the axle will move the door approximately 1/8". Turn the axle clockwise to move the door away from the wall and counterclockwise to bring the door closer to the wall. Tighten the axle nuts securely after adjustment.

#### **b) Bottom Of Door (Fig.D)**

The bottom of the door is adjusted by moving the bottom door guides. Loosen the two bolts on the bottom side of the bottom door guide mounting bracket. While holding the guides against the door guide angle, move the door and guides to the desired position. Tighten the bolts, check that there is enough clearance between the guides to prevent binding of the guide angle.

NOTE: The glide lug should rest on the door guide angle during door travel. If more than 1/8" of the glide lug overhangs the door guide angle, adjust door position so that the glide lug overhangs by no more than 1/8". (1/16" overhang is nominal condition)

### **4) Rear Door Stop (Fig. F)**

The rear door stop locates the door for the proper locked open position. If the lockbar does not drop completely and freely in this position, the rear door stop may need adjustment.

To adjust, loosen the two bolts securing the door stop. Find the point at which the lockbar drops completely and freely. Slide the stop up against the door hanger. Check for proper operation, then torque the bolts to 75 ft/lbs.

## 5) Kick Release Assembly (Fig. B)

The kick release assemblies must be adjusted so that when unlocked, the door moves approximately 1" to 3" (heavier doors will move less than lighter doors). The kick release assembly has been factory adjusted to achieve approximately the desired amount of movement, however some adjustment is usually required.

To adjust the amount of door movement at unlock, loosen the shaft collar set screw and slide the collar in the desired direction as shown in Fig. B. Tighten the set screw securely and check for proper door movement. Readjust as required.

NOTE: The kick release shaft must fully and squarely contact the push bracket on the door hanger. Adjust the push bracket as required and securely fasten push bracket to door hanger.

NOTE: Increased door movement at unlock will increase the force required to turn the key for hip high manual release. For models with hip high manual override, door movement may need to be decreased for ease of manual override operation.

## PNEUMATIC ADJUSTMENTS

### 1) Lock Cylinder Speed (Fig. G)

The lock and kick cylinders are controlled by the same valve assembly. To increase the lock cylinder speed, turn the tee-handle counterclockwise. To reduce the speed (and also noise), turn the tee-handle clockwise. Changes in speed will not have any affect on the amount of force exerted by the air cylinders.

# ELECTRICAL ADJUSTMENTS

## 1) Secure/Unsecure Indication

Position indication is controlled by two switches. Both the door position switch and the lock position switch must be made in order to get a secure indication.

### a) Lock position switch (LS1)

The lock position switch is located in front of and near the bottom of the lock mechanism. When the lock bar is at its lowest point this switch should be depressed. To adjust this switch, place the door in the closed/locked position. The lockbar lifting pin should now be at the bottom end of the Z shaped slot in the horizontal lock slide. Loosen the screws securing the lock position switch. Lower the switch away from the lifting pin. Then slowly raise the switch until the contacts close (switch will click at this point). (See Fig. H)

### b) Door position switch (LS2)

The door position switch is located on the actuator near the receiving column. It should be fully depressed when the door is in the closed/locked position. Pulling the door against the lockbar (away from the receiving column) should not release the door position switch. To adjust this switch, loosen the nut securing the switch mounting bracket to the actuator. Position the door in the closed/locked position. Hold the door against the lockbar towards the open position. Position the switch so that it is fully depressed and tighten the nut.( See Fig. H)

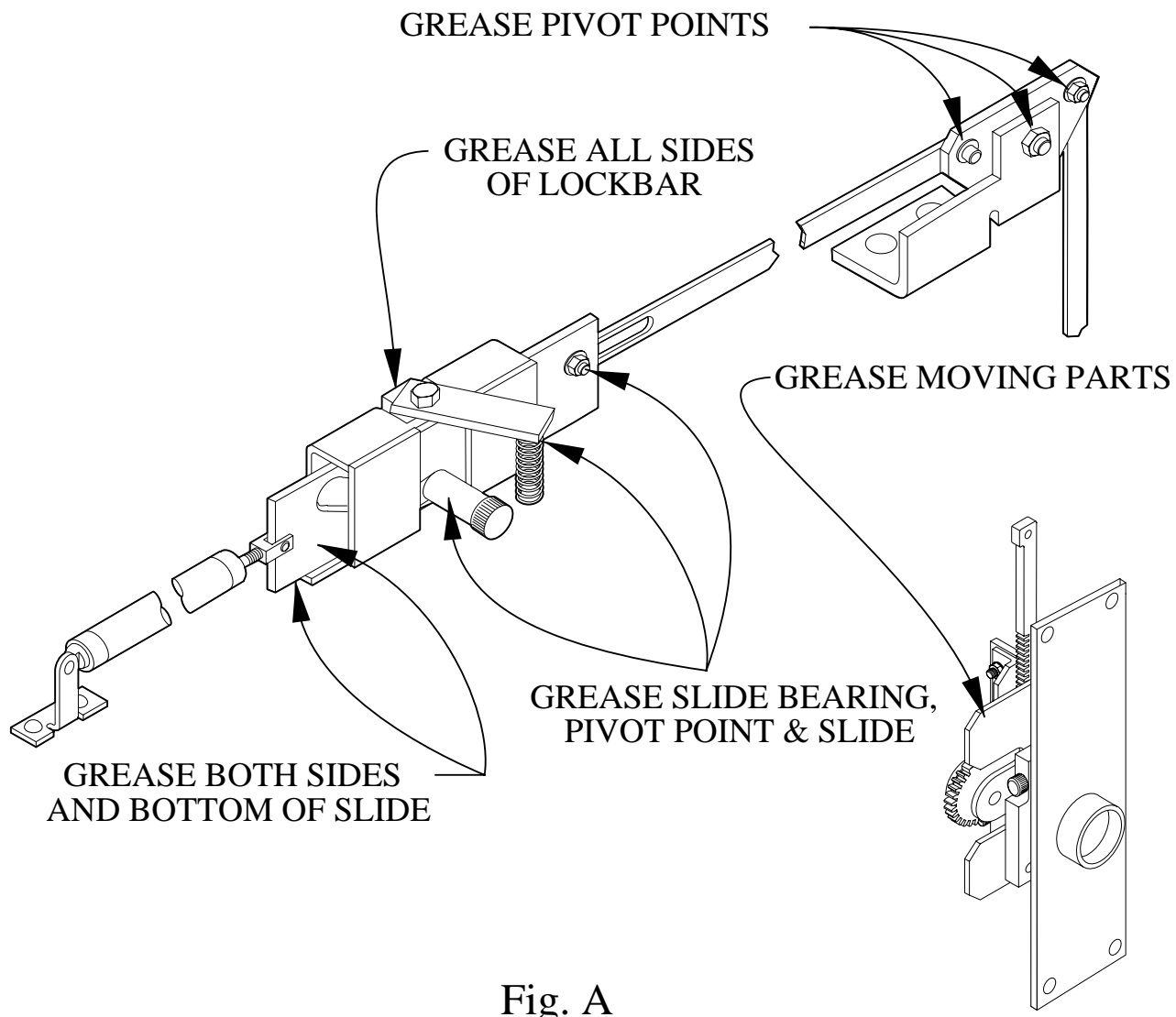

Fig. A

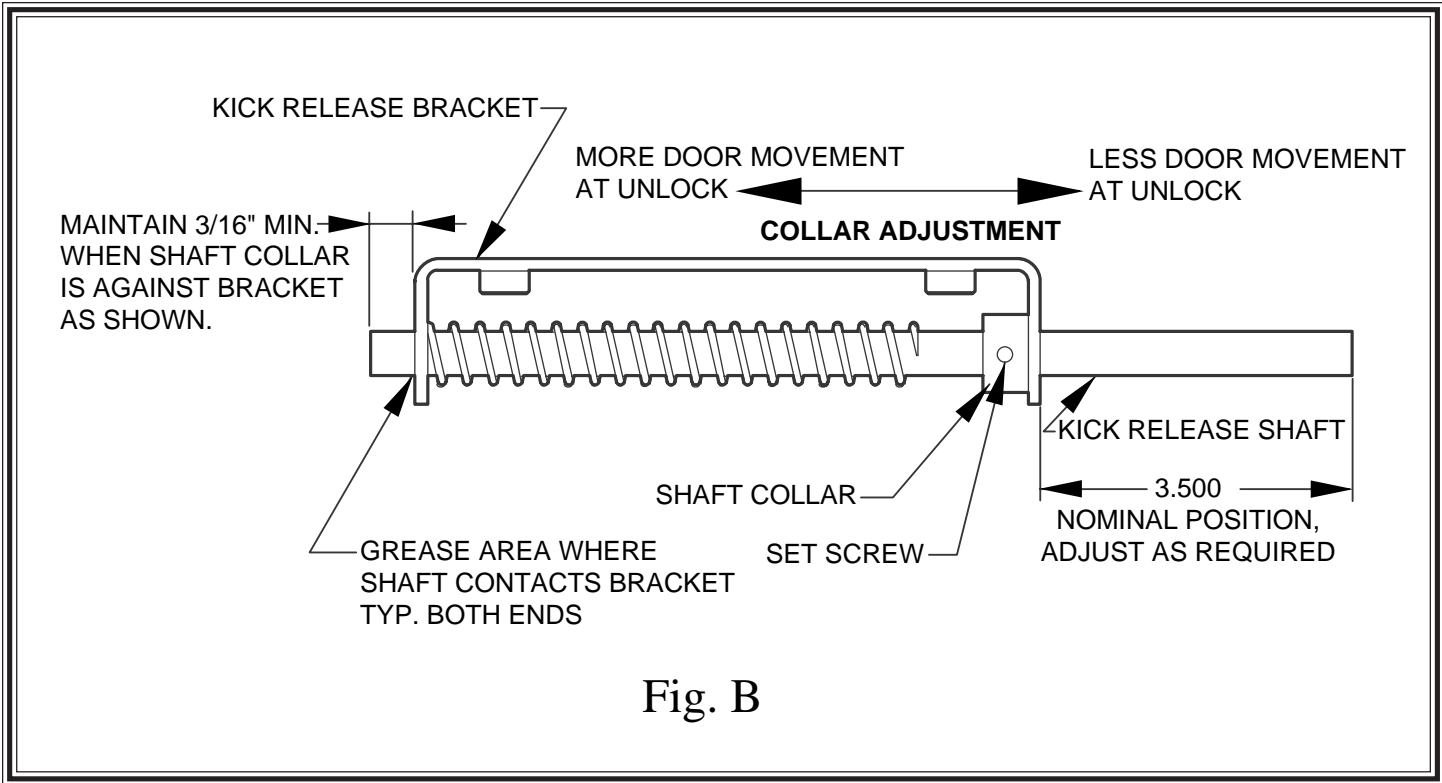

Fig. B

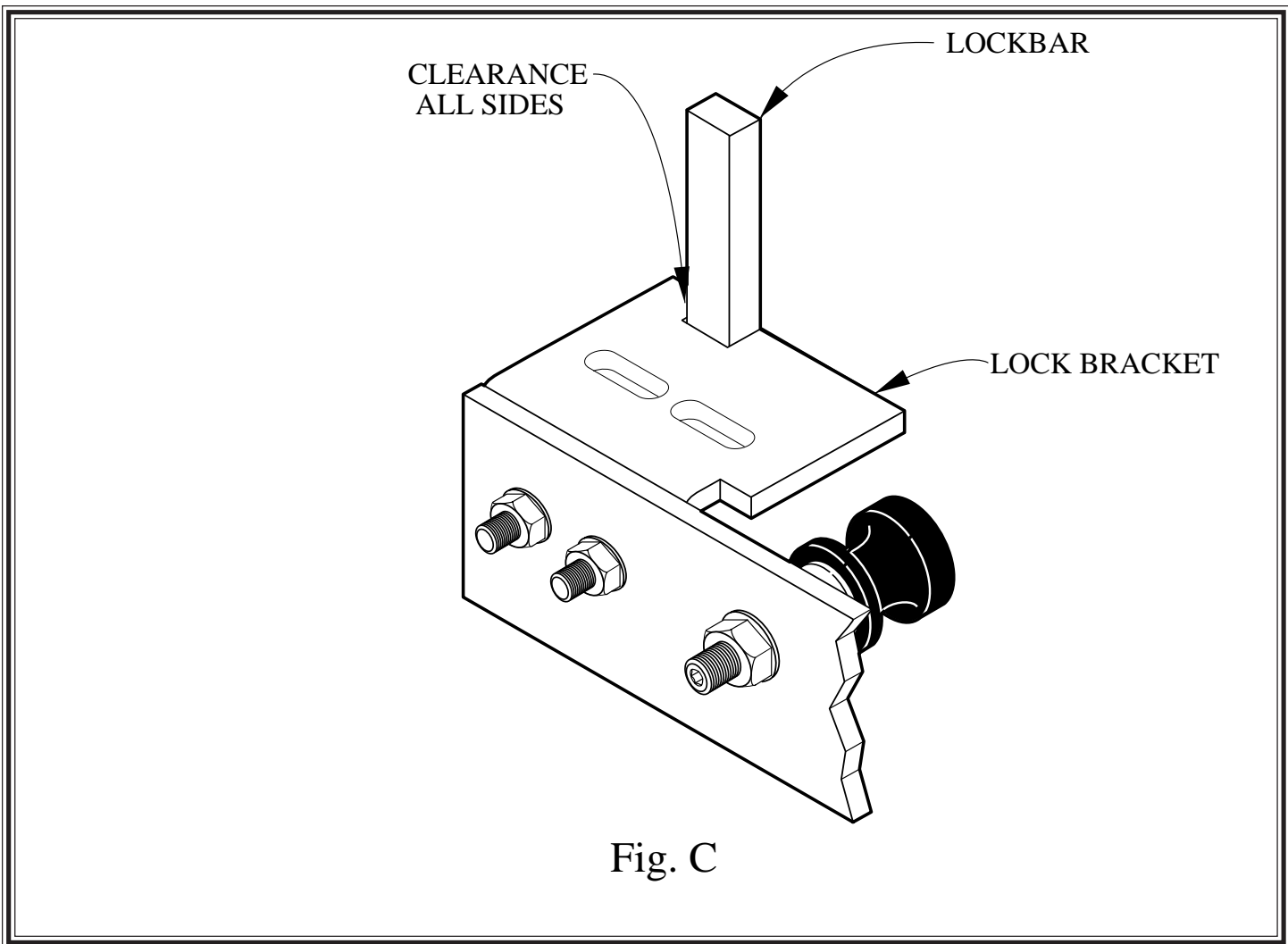

Fig. C

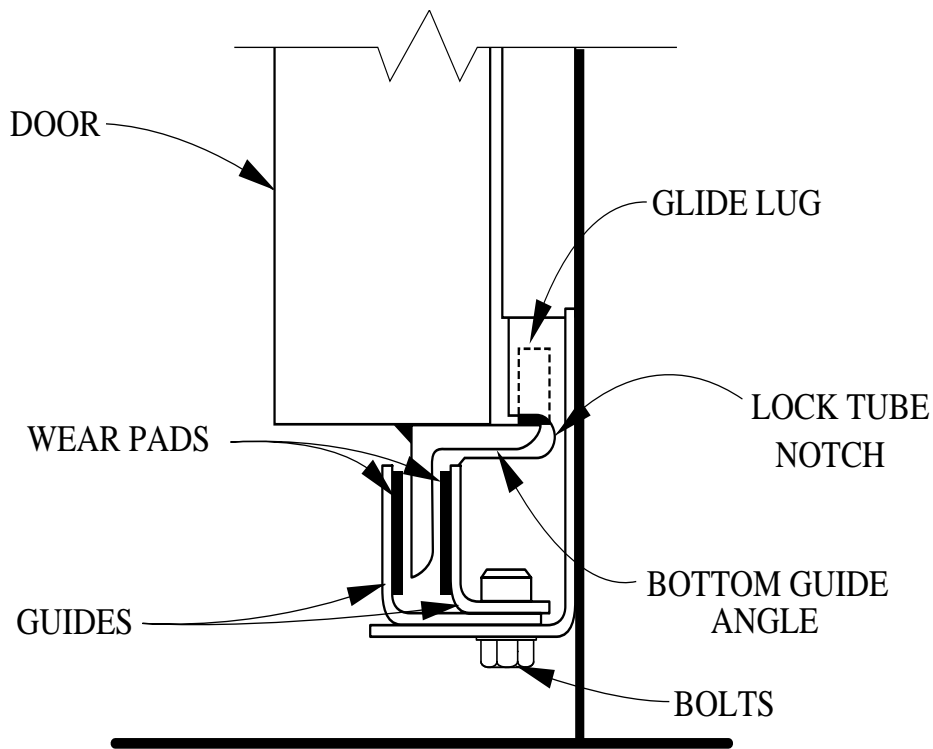

Fig. D

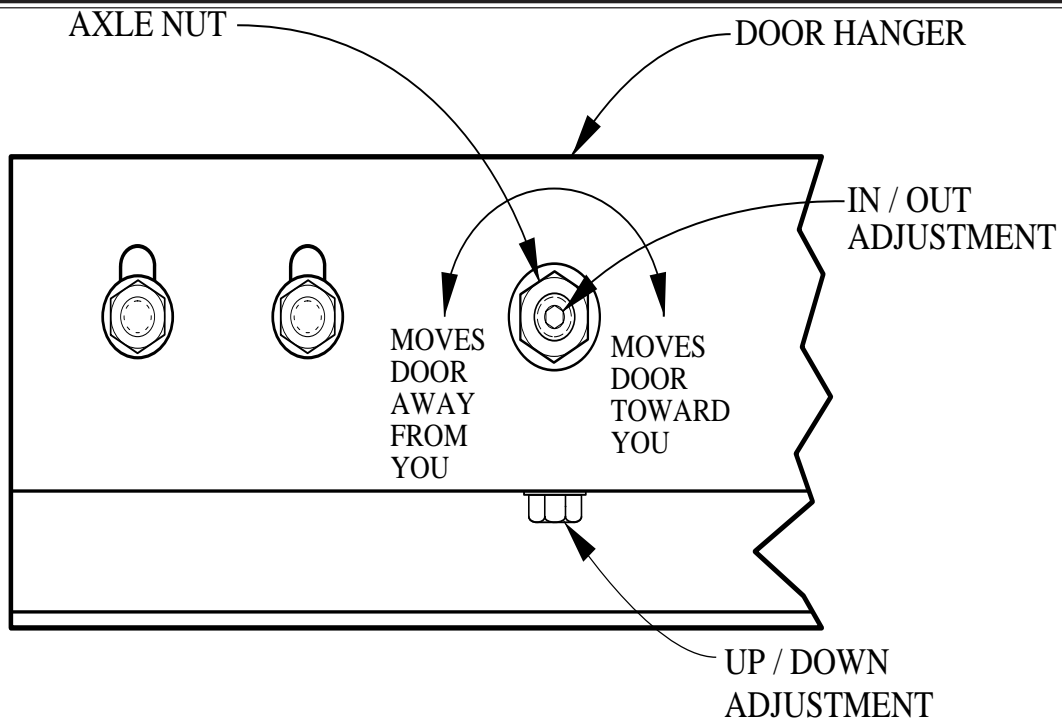

Fig. E

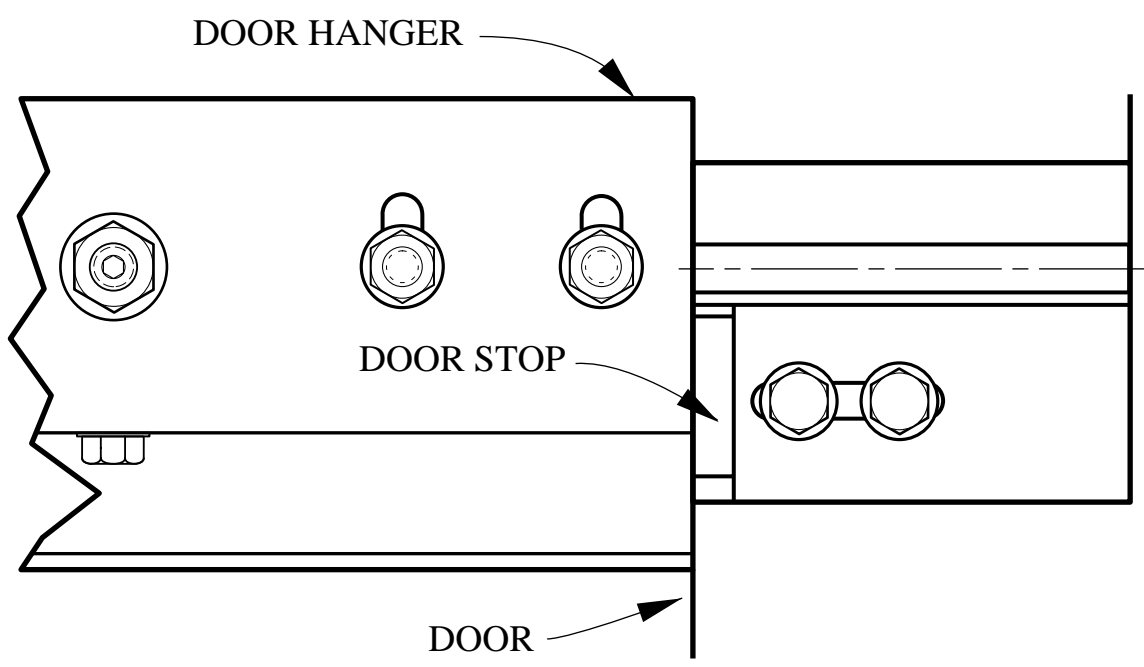
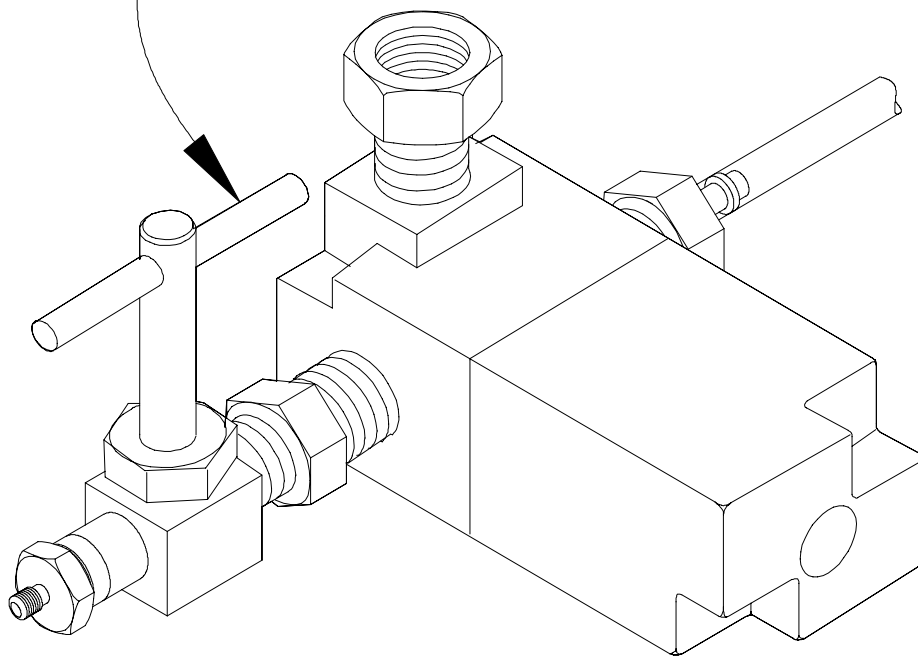

Fig. F



**LOCK CYLINDER  
SPEED ADJUSTMENT**



**Fig. G**

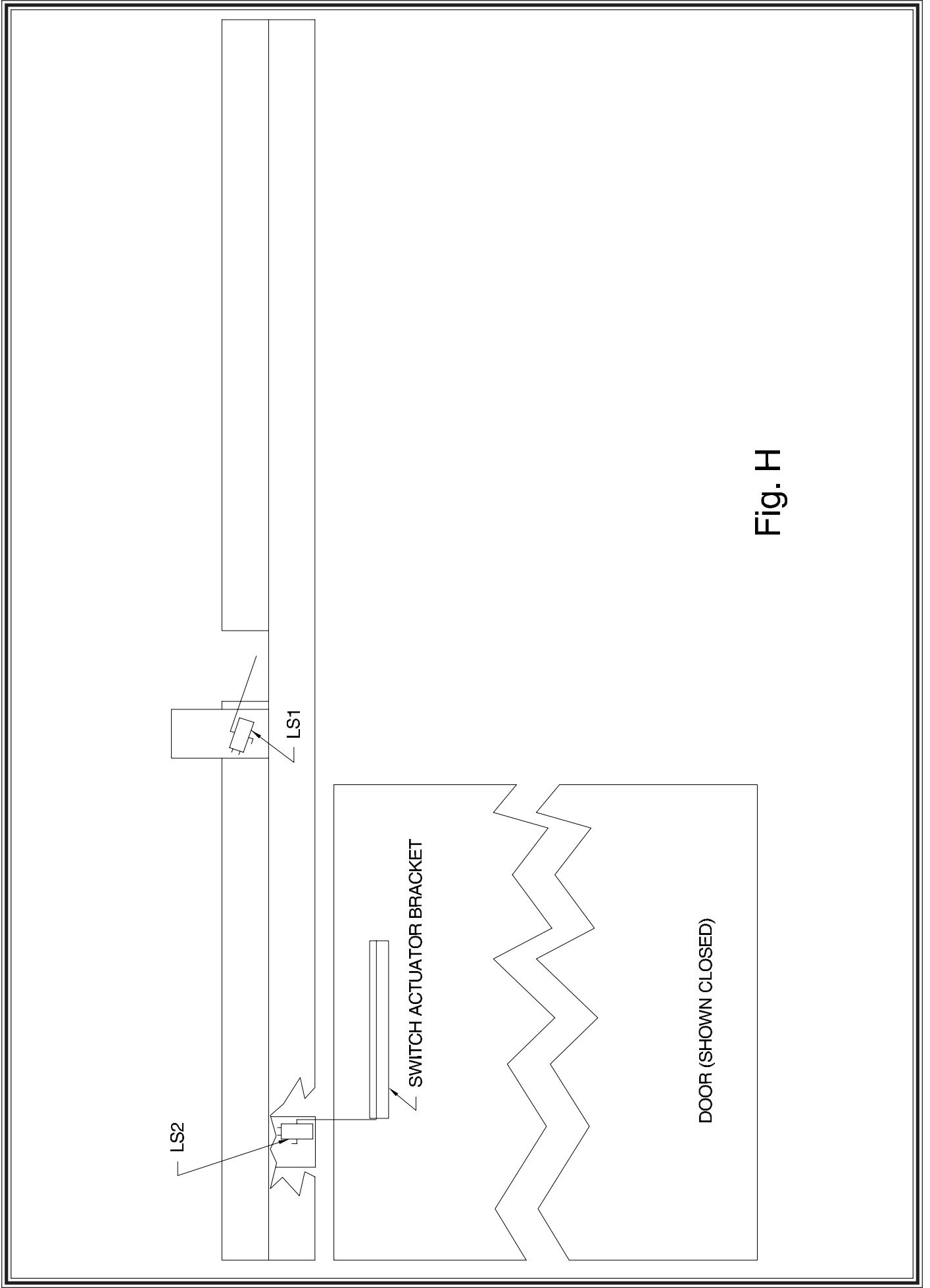

Fig. H