



**AIRTEQ**

www.airteq.com

800-466-3007

## 9924 SERIES LOCK

9924 2-15

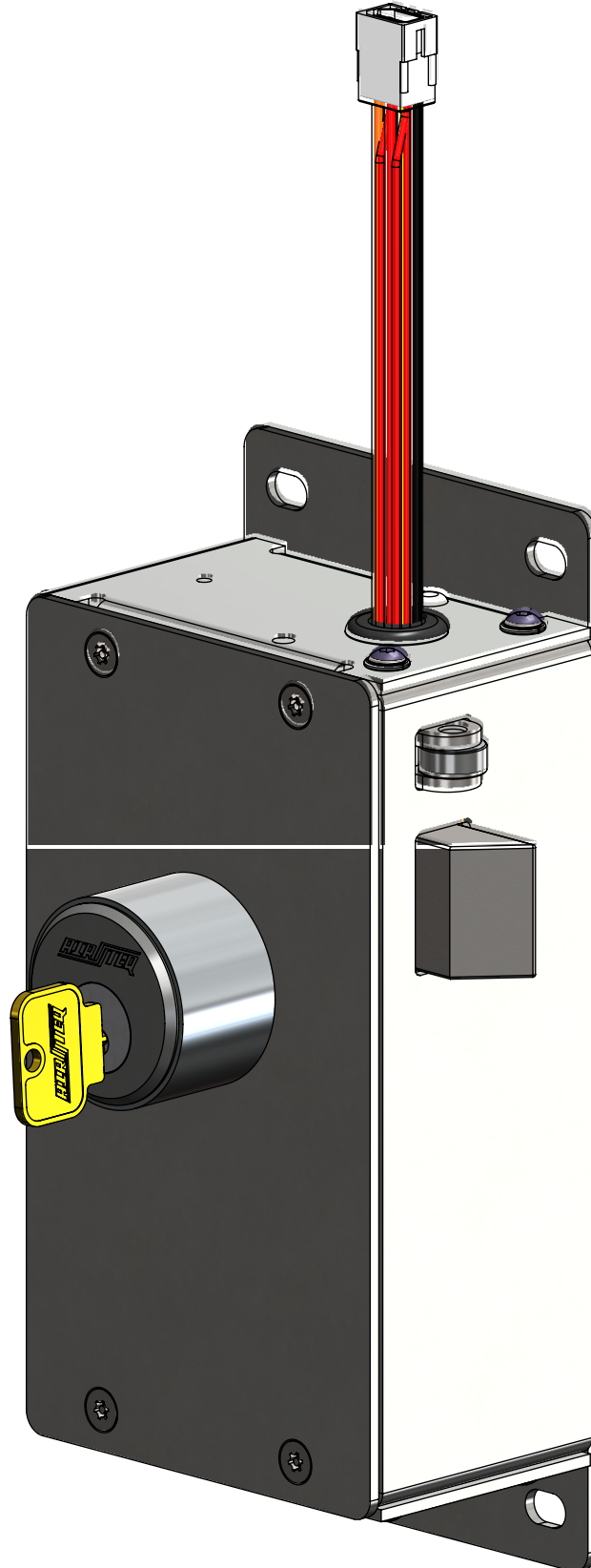

ITEM NO.	PART NUMBER	DESCRIPTION
1	10002511	Shoulder Screw Ø3/8"x1 1/4", 5/16-18 Nylock
2	10002513	Shoulder Screw Ø3/8"x3/8", 5/16-18 Nylock
3	10003203	Spring Anchor, 7/8in, 8-32x5/8 Thread, Black Oxide
4	10003204	Hook End Ext. Spring, .375"OD, 2.5"Length
5	146-9900-107L	Actuator Assembly, Left Hand
6	146-9900-107R	Actuator Assembly, Right Hand
7	146-9900-107SL	Solenoid Lock Actuator Assembly, Left Hand
8	146-9900-107SR	Solenoid Lock Actuator Assembly, Right Hand
9	146-9900-122	Latchbolt Assembly
10	146-9900-124L	Left Hand Deadlatch Assembly
11	146-9900-124R	Right Hand Deadlatch Assembly
12	146-9900-125L	Deadlatch Catch Indication Assembly, LH
13	146-9900-125R	Deadlatch Catch Indication Assembly, RH
14	146-9900-126L	Deadlatch Pivot / Lock Status Switch Mount Assembly, LH
15	146-9900-126R	Deadlatch Pivot / Lock Status Switch Mount Assembly, RH
16	146-9900-272	9900 Key Switch Assembly, Keyed Two Sides
17	146-9912M-100L	9900 120VAC Left Hand Motor Assembly
*17*	146-9912M-100L-HC	Half Cycle, 9900 120VAC Left Hand Motor Assembly
18	146-9912M-100R	9900 120VAC Right Hand Motor Assembly
*18*	146-9912M-100R-HC	Half Cycle, 9900 120VAC Right Hand Motor Assembly
19	146-9912S-100	9900 120VAC Solenoid Assembly
20	146-9924M-100L	9900 24VDC Left Hand Motor Assembly
*20*	146-9924-100L-HC	Half Cycle, 9900 24VDC Left Hand Motor Assembly
21	146-9924M-100R	9900 24VDC Right Hand Motor Assembly
*21*	146-9924-100R-HC	Half Cycle, 9900 24VDC Right Hand Motor Assembly
22	150-9900-110L	Side Housing Weldment, Left Hand Lock
23	150-9900-110R	Side Housing Weldment, Right Hand Lock
24	160-9912M-100	9912M Main Wiring Harness
25	160-9912S-100	9912S Main Wiring Harness
26	160-9924-100	9924 Main Wiring Harness
27	216-1000-028	Mogul Cylinder, SPANNER Lock NUT
28	216-9900-100	Main Housing Back
29	216-9900-102	Back Mounting Plate Keyed Back Side
30	216-9900-105	Cover Plate
31	216-9900-217	Deadlatch Cushion
32	216-9900-220L	Spring Support Base, LH
33	216-9900-220R	Spring Support Base, RH
34	216-9900-255	RLB Arm
35	310-2520-001	BOLT, HEX HD, 1/4-20 X .62 LG, STL, PLATED
36	310-2520-004	BOLT, HEX, HD, 1/4-20 X .38 LG, STL, PLATED
37	310-2520-045	Screw, BHCS, 1/4-20 X 3/8, Black Oxide
38	310-3100-000	Shoulder Screw, Ø5/16"x3/8, 1/4-20x7/16
39	311-2520-082	Screw, FH, Pin TORX, 1/4-20x1/2, Stainless Steel, UC Head
40	312-3118-004	Thin "Jam" 5/16-18 Nylock nut. McMaster 94945A213 or eq.
41	313-3100-005	5/16in D Washer McMaster 96025A167 or Eq.
41	313-0000-003	WSHR, LOCK, SPLIT, 1/4, STL, PLTD
43	313-0000-120	Fender Washer
44	315-9900-001	Spring, .485"OD x 2.25" Length
45	315-9900-002	Spring, .405"OD x 2.25" Length
46	315-9900-005	.60"ODx1.25"length
47	315-9900-010	RLB Catch, Left Hand Torsion Spring
48	315-9900-011	RLB Catch, Right Hand Torsion Spring
49	315-9900-021	Actuator 360° Right Hand Torsion Spring
50	315-9900-022	Actuator 360° Left Hand Torsion Spring
51	340-0000-170	Anchor Mount Cable Tie Holder
52	340-0000-204	Cable Tie, 4in

REVISIONS				
ECN #	REV.	DESCRIPTION	DATE	APPROV.
	A	Initial Release	11/17/14	
	B	Cumulative: Hex Head motor/sol. mounting screws, add 313-0000-120, add 216-9900-217 for Sol. locks, etc.	10/27/15	
	C	Added Half Cycle Part Numbers, 216-9900-205 Now Part of Motor Assemblies	1/25/18	

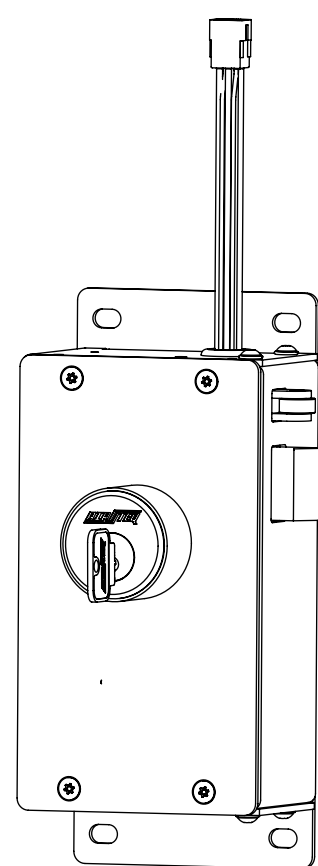

9900 Series Lock LH

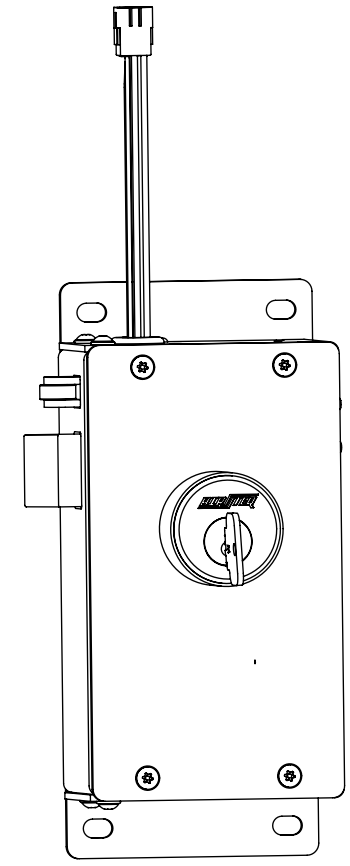

9900 Series Lock RH

NOTES:

- 146-9900-126L may be substituted for 146-9900-125L in left hand motor locks
- 146-9900-126R may be substituted for 146-9900-125R in right hand motor locks
- Same length button head cap screws may be used in place of hex head cap screws to mount motor/solenoid assemblies to lock body. Specifically item numbers 36 (used to mount solenoid assemblies) and 37 (used to mount motor assemblies)

DRAWN	DATE	NAME	
CHECKED	11/17/14	RLP	
TITLE: <b>9900 Series 120VAC/24VDC Motor &amp; 120VAC Solenoid Lock</b>			
FINISH:	SIZE	DWG. NO.	REV
	<b>A</b>	9912M / 9924M / 9912S	<b>C</b>
SCALE: 1:4			SHEET 1 OF 7

REVISIONS				
ECN #	REV.	DESCRIPTION	DATE	APPROV.
	A	Initial Release	11/14/14	
	B	Cumulative: Hex Head motor/sol. mounting screws, add 313-0000-120, add 216-9900-217 for Sol. locks, etc.	10/27/15	
	C	Added Half Cycle Part Numbers, 216-9900-205 now a part of motor assemblies	1/25/18	

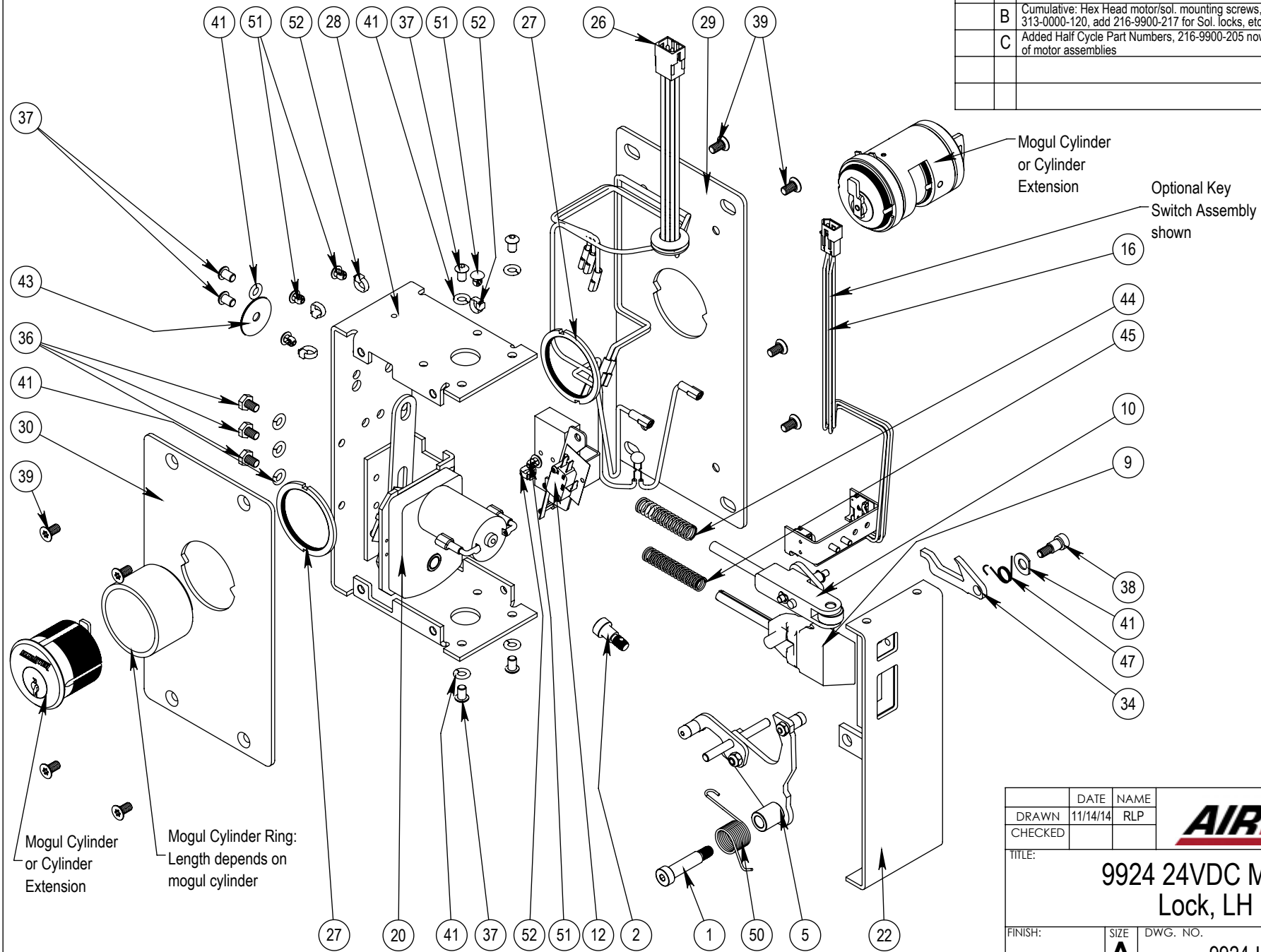

	DATE	NAME	
DRAWN	11/14/14	RLP	
CHECKED			
TITLE:			
<b>9924 24VDC Motor Lock, LH</b>			
FINISH:	SIZE	DWG. NO.	REV
	<b>A</b>	9924-LH	<b>C</b>
SCALE: 1:4			SHEET 4 OF 7





**AIRTEQ**

www.airteq.com  
800-466-3007

# 9924 SERIES LOCK

9924 11-28

## RECOMMENDED SPARE PARTS

ITEM NO.	PART NUMBER	Description Spare Parts
1	160-9924-100	9924 Wiring Harness
2	160-9924-105	9924 Lock, Motor
3	160-9900-150*	Half Cycle Motor Switches and Pigtail*
4	315-9900-001	Dead Latch Spring
5	315-9900-002	Latch Bolt Spring
6	315-9900-010	RLB Spring, LH Lock
7	315-9900-011	RLB Spring, RH Lock
8	315-9900-021	Actuator Spring, RH Lock
9	315-9900-022	Actuator Spring, LH Lock
10	340-9900-002	Roller Arm Switch
11	82008802	99 Series Lock Status Switch

\*For Half Cycle Locks, 160-9900-150 replaces 340-9900-002

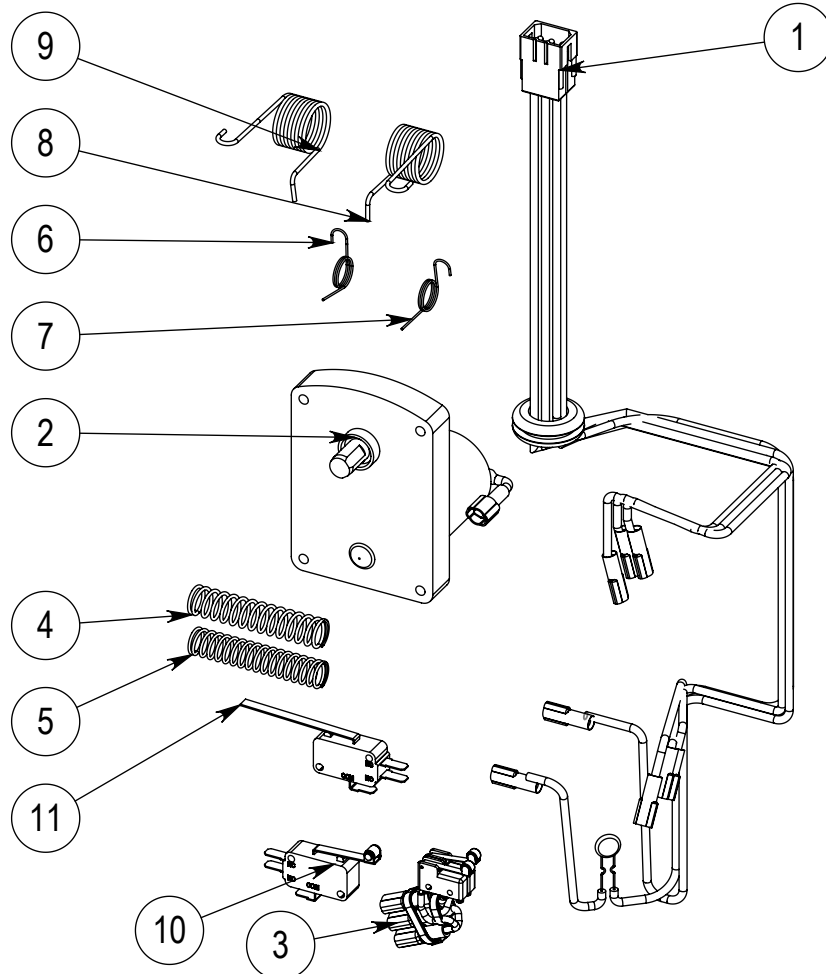

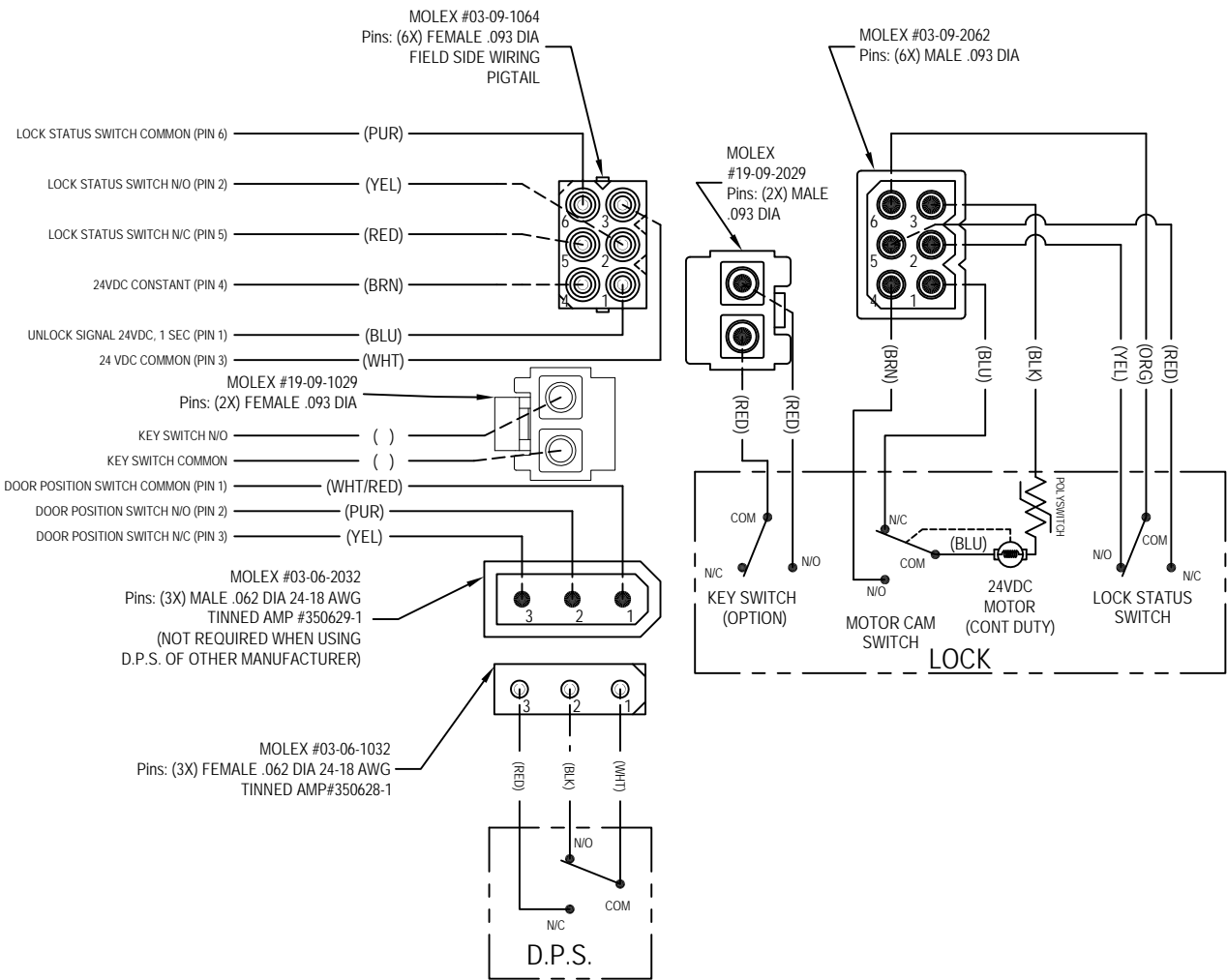

REV	ECN	DESCRIPTION	DRAWN	CHK

- NOTES:
1. MOTOR CURRENT: 24VDC 3.5A INRUSH, .32A RUNNING
  2. SWITCH CONTACTS: 5A.
  3. SCHEMATIC SHOWN WITH DOOR IN THE CLOSED AND LOCKED (SECURE) POSITION.
  4. PLUGS AND RECEPTACLES INSIDE LOCK NOT SHOWN.
  5. FOR SERIES LOCK STATUS AND DOOR POSITION SWITCH OPERATION, CONNECT LOCK FIELD SIDE YELLOW WIRE (LOCK STATUS SWITCH N/O) AND DPS FIELD SIDE PURPLE WIRE (DPS SWITCH N/O). CHECK CONTINUITY BETWEEN LOCK FIELD SIDE PURPLE (LOCK STATUS SWITCH COM) AND DPS FIELD SIDE WHT/RED (DPS SWITCH COM).
  6. ALWAYS INSTALL IN ACCORDANCE WITH LOCAL REGULATIONS AND THE NATIONAL ELECTRIC CODE (NEC).
  7. GROUND LOCK CASE IN ACCORDANCE WITH ARTICLE 250 OF THE NATIONAL ELECTRICAL CODE

COMPANY CONFIDENTIAL: THIS DRAWING IS THE PROPERTY OF AIRTEQ SYSTEMS AND MUST BE ACCOUNTED FOR. INFORMATION HEREON IS CONFIDENTIAL AND MUST NOT BE USED, REPRODUCED, REVEALED TO UNAUTHORIZED PERSONS OR SENT OUTSIDE THE COMPANY WITHOUT PROPER AUTHORIZATION.



<b>TITLE</b> WIRING DIAGRAM 9924 24VDC MOTOR LOCK	<b>DRAWN BY</b> RLP		
	<b>APPROVED</b>		
	<b>DATE</b> 4/9/14		
	<b>SCALE</b> NONE		
<b>©1989 AIRTEQ SYSTEMS.</b>	<b>SIZE</b> B	<b>DWG. NO.</b> EL-9924	<b>REV</b> A

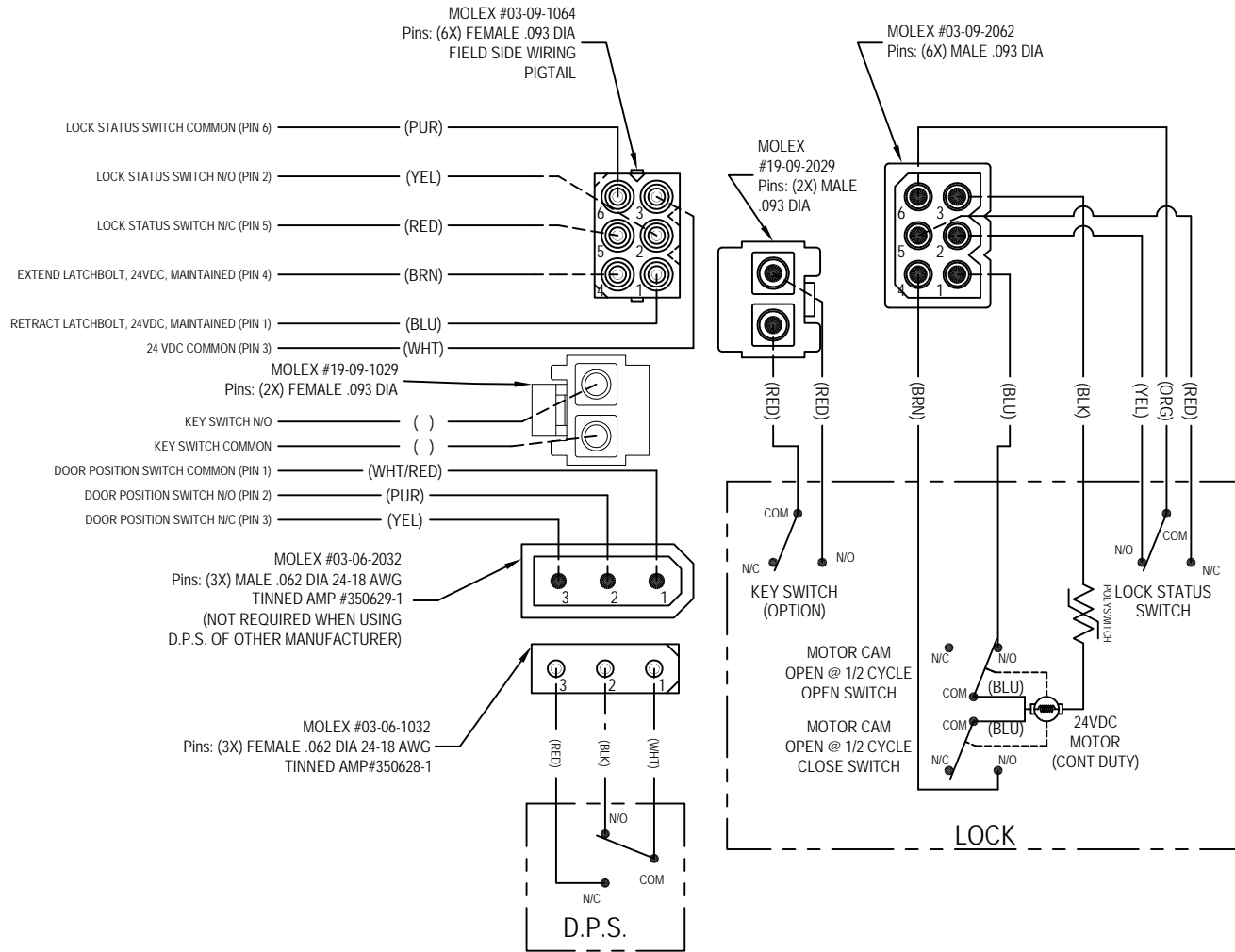

REV	ECN	DESCRIPTION	DRAWN	CHK

NOTES:

1. MOTOR CURRENT: 24VDC 3.5A INRUSH, .32A RUNNING
2. SWITCH CONTACTS: 5A.
3. SCHEMATIC SHOWN WITH DOOR IN THE CLOSED AND LOCKED (SECURE) POSITION.
4. PLUGS AND RECEPTACLES INSIDE LOCK NOT SHOWN.
5. FOR SERIES LOCK STATUS AND DOOR POSITION SWITCH OPERATION, CONNECT LOCK FIELD SIDE YELLOW WIRE (LOCK STATUS SWITCH N/O) AND DPS FIELD SIDE PURPLE WIRE (DPS SWITCH N/O). CHECK CONTINUITY BETWEEN LOCK FIELD SIDE PURPLE (LOCK STATUS SWITCH COM) AND DPS FIELD SIDE WHT/RED (DPS SWITCH COM).
6. ALWAYS INSTALL IN ACCORDANCE WITH LOCAL REGULATIONS AND THE NATIONAL ELECTRIC CODE (NEC).
7. GROUND LOCK CASE IN ACCORDANCE WITH ARTICLE 250 OF THE NATIONAL ELECTRICAL CODE

COMPANY CONFIDENTIAL: THIS DRAWING IS THE PROPERTY OF AIRTEQ SYSTEMS AND MUST BE ACCOUNTED FOR. INFORMATION HEREON IS CONFIDENTIAL AND MUST NOT BE USED, REPRODUCED, REVEALED TO UNAUTHORIZED PERSONS OR SENT OUTSIDE THE COMPANY WITHOUT PROPER AUTHORIZATION.



<b>TITLE</b> WIRING DIAGRAM 9924 24VDC RLHB MOTOR LOCK, HALF CYCLE	<b>DRAWN BY</b> RLP		
	<b>APPROVED</b>		
	<b>DATE</b> 4/9/14		
	<b>SCALE</b> NONE		
<b>©1989 AIRTEQ SYSTEMS.</b>	<b>SIZE</b> B	<b>DWG. NO.</b> EL-9924-HC	<b>REV</b> A

INDICATION LIGHT WIRE:  
 24VDC COMMON (-) for Cathode Common LED – (BLK)  
 OR 24VDC (+) for Anode Common LED

LOCK STATUS INDICATION POWER CONNECTION. USER MUST SPECIFY INDICATION POWER SCHEME EITHER:

+24VDC INDICATION POWER (Cathode Common LED Light)

OR  
 24VDC COMMON (-) INDICATION POWER (Anode Common LED Light)

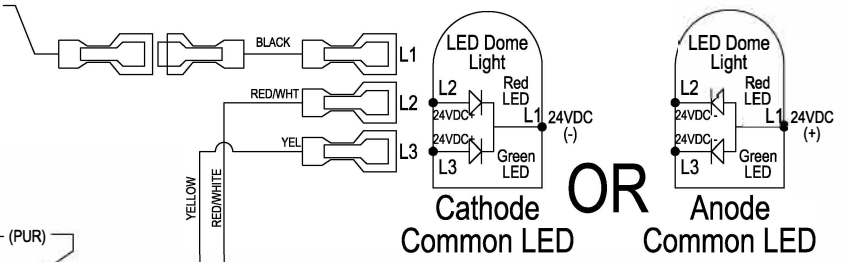
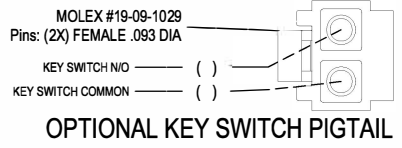
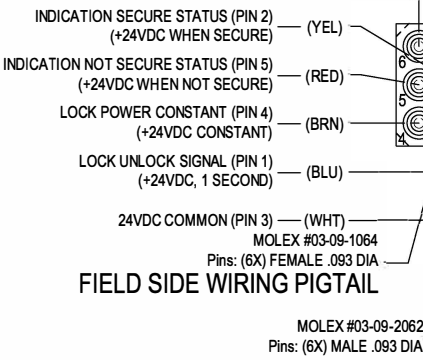

**USER MUST SPECIFY INDICATION VOLTAGE SCHEME**

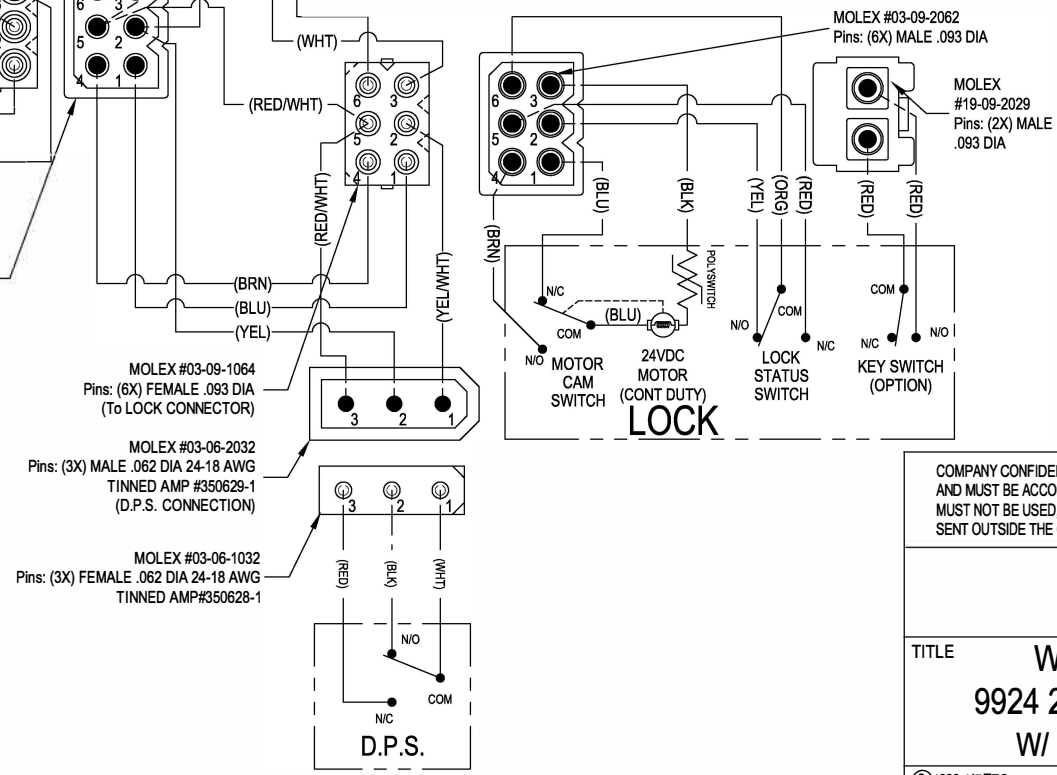

REVISIONS				
REV	ECN	DESCRIPTION	DRAWN	CHK

- NOTES:
1. MOTOR CURRENT: 24VDC 3.5A INRUSH, .32A RUNNING
  2. SWITCH CONTACTS: 5A.
  3. SCHEMATIC SHOWN WITH DOOR IN THE CLOSED AND LOCKED (SECURE) POSITION.
  4. PLUGS AND RECEPTACLES INSIDE LOCK NOT SHOWN.
  5. LOCK INDICATION POWER CIRCUIT IS 24VDC. HOWEVER, USER MUST SPECIFY CATHODE COMMON OR ANODE COMMON INDICATION SCHEME AS SHOWN.
  6. SUPPLYING 120VAC TO INDICATION CIRCUIT WILL CAUSE CATASTROPHIC FAILURE OF INDICATION COMPONENTS
  7. ALWAYS INSTALL IN ACCORDANCE WITH LOCAL REGULATIONS AND THE NATIONAL ELECTRIC CODE (NEC).
  8. GROUND LOCK CASE IN ACCORDANCE WITH ARTICLE 250 OF THE NATIONAL ELECTRICAL CODE

COMPANY CONFIDENTIAL: THIS DRAWING IS THE PROPERTY OF AIRTEQ SYSTEMS AND MUST BE ACCOUNTED FOR. INFORMATION HEREON IS CONFIDENTIAL AND MUST NOT BE USED, REPRODUCED, REVEALED TO UNAUTHORIZED PERSONS OR SENT OUTSIDE THE COMPANY WITHOUT PROPER AUTHORIZATION.



TITLE		DRAWN BY	
WIRING DIAGRAM		RLP	
9924 24VDC MOTOR LOCK		APPROVED	
W/ RED/GREEN LIGHT		DATE 9/18/18	
©1989 AIRTEQ SYSTEMS.		SCALE	NONE
SIZE	DWG. NO.	REV	
B	EL-9924-RGL-U	A	

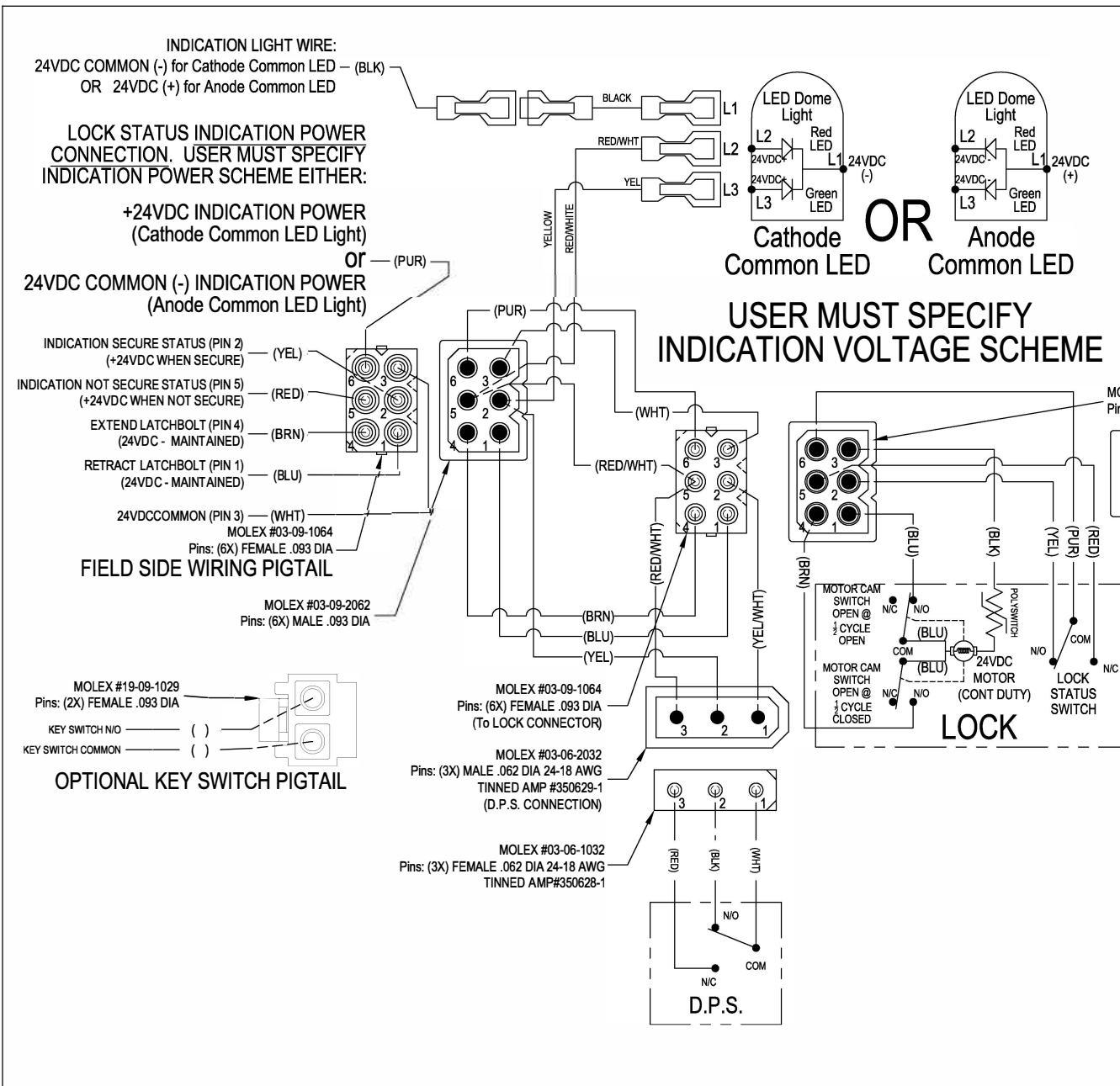

REVISIONS				
REV	ECN	DESCRIPTION	DRAWN	CHK

- NOTES:**
- MOTOR CURRENT: 24VDC 3.5A INRUSH, .32A RUNNING
  - SWITCH CONTACTS: 5A.
  - SCHEMATIC SHOWN WITH DOOR IN THE CLOSED AND LOCKED (SECURE) POSITION.
  - PLUGS AND RECEPTACLES INSIDE LOCK NOT SHOWN.
  - LOCK INDICATION POWER CIRCUIT IS 24VDC. HOWEVER, USER MUST SPECIFY CATHODE COMMON OR ANODE COMMON INDICATION SCHEME AS SHOWN.
  - SUPPLYING 120VAC TO INDICATION CIRCUIT WILL CAUSE CATASTROPHIC FAILURE OF INDICATION COMPONENTS
  - ALWAYS INSTALL IN ACCORDANCE WITH LOCAL REGULATIONS AND THE NATIONAL ELECTRIC CODE (NEC).
  - GROUND LOCK CASE IN ACCORDANCE WITH ARTICLE 250 OF THE NATIONAL ELECTRICAL CODE

COMPANY CONFIDENTIAL: THIS DRAWING IS THE PROPERTY OF AIRTEQ SYSTEMS AND MUST BE ACCOUNTED FOR. INFORMATION HEREON IS CONFIDENTIAL AND MUST NOT BE USED, REPRODUCED, REVEALED TO UNAUTHORIZED PERSONS OR SENT OUTSIDE THE COMPANY WITHOUT PROPER AUTHORIZATION.



TITLE		DRAWN BY	
WIRING DIAGRAM		RLP	
9924 24VDC RLHB MOTOR LOCK		APPROVED	
Half Cycle w/RED/GREEN Light		DATE 9/18/18	
		SCALE NONE	
©1989 AIRTEQ SYSTEMS.	SIZE B	DWG. NO. EL-9924-HC-RGL-U	REV A



**9924 SERIES  
LOCK MAINTENANCE  
INFORMATION**

## A. Lubrication and Cleaning

1. Each lock is well lubricated at the time of assembly. However, all lubricants deteriorate eventually and need replacing on a regularly scheduled basis to prevent equipment failure. Airteq Systems recommends cleaning and lubricating each type of lock according to the following instructions approximately every (2) years. (Yearly for locks in high use areas, every 3 to 6 months for exterior locations).
2. General Lubrication:
  - i. Remove lock cover plate and back plate.
  - ii. Wipe contaminated/dirty surfaces and remove all foreign material
  - iii. Lubricate the following areas with Super Lube grease or equivalent (Synthetic lubricant with PTFE aka Teflon):
    - Latch bolt and deadlatch surfaces where they exit the lock body and at the back 'shafts' where they enter the guide base.
    - Actuator Pivot and Arm where Actuator contacts latch bolt pin
    - Dead latch lever where it contacts lock body front and top of actuator
    - RLB arm surface where it contacts the actuator roller
    - Actuator roller sleeves
    - Any other metal on metal sliding surfaces
    - Latch bolt beveled surface and strike may be lubricated with stick lubricant as required. Use PANEF WHITE STICK LUBRICANT WITH SILICONE or equivalent.
3. WARNING
  - i. Never use WD40 or similar silicone based products as a lubricant
  - ii. Never use graphite powder

## B. Mechanical

1. Check Deadlock Function
  - i. Press Deadlatch into lock face until DL Link clears Actuator Arm
  - ii. Verify Actuator Arm rotates and Contacts lock face
  - iii. Verify DL Rocker rotates up completely (blocking latch bolt pin)
  - iv. Verify Latchbolt is physically prevented from being pushed into the lock by the DL Rocker (i.e. Lock is Deadlocked).
  - v. If lock does NOT mechanically Deadlock, troubleshoot and correct before returning lock into service.
2. Check Not Deadlock Function
  - i. Release Deadlatch
  - ii. Verify DL Link pushes Actuator Arm away from Lock Face
  - iii. Verify DL Rocker rotates down (completely clearing Latchbolt pin)
  - iv. Verify Latch Bolt can freely be pushed into the lock face (i.e. Lock is NOT Deadlocked)
  - v. If lock does NOT come out of mechanical deadlock when the deadlatch is released, troubleshoot and correct before returning lock into service.

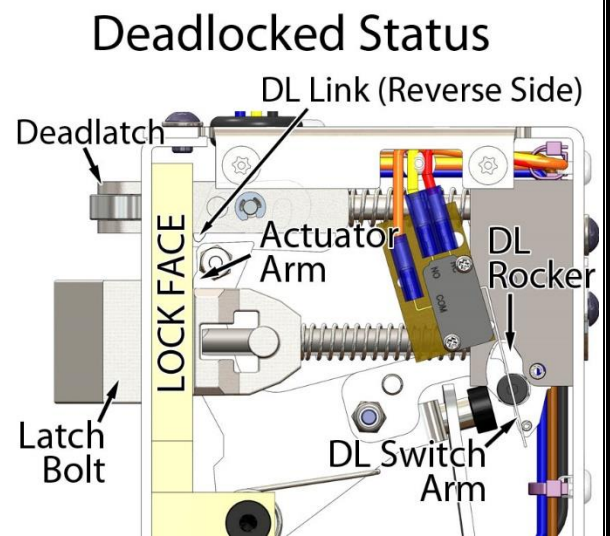

### 3. Motor or Solenoid Position

- i. Verify when motor or solenoid activate that latch bolt pulls back completely
  - a. Adjust Motor/Solenoid position down if latch bolt doesn't pull back far enough
- ii. Verify when motor or solenoid returns to locked position that the latch bolt is completely out, and the actuator can rotate into the deadlock position
  - a. Adjust Motor/Solenoid position up if actuator is restrained from rotating into the deadlock position

### C. Electrical

1. The electrical actuation system of this lock is designed for a regulated 24VDC( $\pm 2V$ ) power supply. Any other voltage and/or 24VDC power supply that does not maintain 24VDC with the range specified is not acceptable.
2. Deadlock status switch function must be checked during regular lock maintenance/ lubrication.
  - i. VERIFY CORRECT MECHANICAL DEADLOCKING OPERATION FIRST (Steps B.1 and B.2 above)
  - ii. With lock deadlocked, the DL switch arm should activate the switch:
    - a. Via multi-meter, there SHOULD be continuity between switch COM & NO terminals
    - b. Via multi-meter, there SHOULD NOT be continuity between switch COM & NC terminals
  - iii. With lock NOT deadlocked, the DL switch arm should NOT be activating the switch.
    - a. Via multi-meter, there SHOULD be continuity between switch COM & NC terminals
    - b. Via multi-meter, there SHOULD NOT be continuity between switch COM & NO terminals
  - iv. If the switch arm is not correctly positioned to actuate the switch during mechanical deadlock, and to release the switch when NOT mechanically deadlocked, adjust/slightly bend the switch arm.
  - v. If the switch does not switch and/or release correctly even with proper switch arm adjustment, replace the switch
  - vi. NOTE: THE SWITCH MUST REGISTER NOT DEADLOCKED (Step C.2.iii) IN ANY CASE WHERE THE LOCK IS NOT MECHANICALLY DEADLOCKED. If the lock installation/door position/door gap does not press the deadlatch sufficiently to activate the lock's mechanical deadlocking function, correct the mechanical position of the door/lock until complete mechanical deadlocking is accomplished. DO NOT ADJUST THE DEADLOCK STATUS SWITCH TO INDICATE A DEADLOCK CONDITION WHEN THE LOCK IS NOT MECHANICALLY DEADLOCKED.

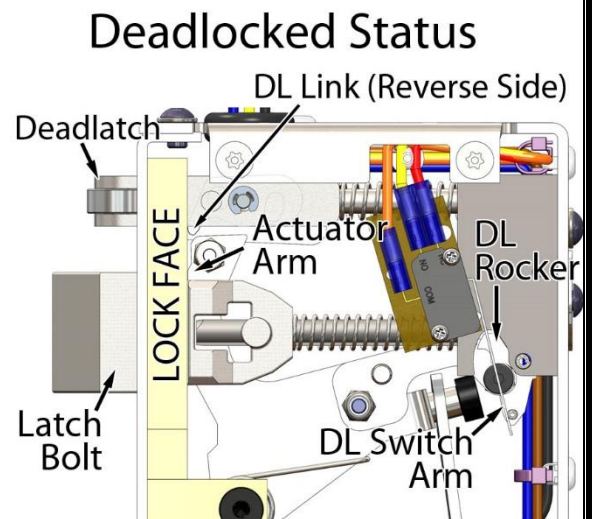

## TROUBLESHOOTING

If the lock is not working properly, the following chart may be used as a guide to locate and correct the problem.

Because the lock receives its power from the electronic control systems, a thorough check of the control system should be conducted. Using a volt/ohm meter know to be accurate, verify the correct power inputs at the appropriate connector pin(s). If the proper electronic signal is not evident, begin checking “up-stream” from the connector. If the electronic signal input is correct, the problem is within the locking device, use the following chart to locate and correct the problem.

The recommended voltage at the lock is 24VDC(±2V). If the correct voltage is not evident, begin checking “upstream” from the lock. If the voltage is correct, the problem is within the locking device. Use the following chart to locate and correct the problem.

PROBLEM	CHECK
LATCHBOLT WILL NOT RETRACT	Mechanical Interference Poor on No Power to the Lock Broken or loose wiring Faulty Key Switch
LATCHBOLT WILL NOT EXTEND	Mechanical Interference Broken or loose wiring Faulty Key Switch
LOCK RETRACTS BUT WITH LOW STALL FORCE	Bad Motor or Lock Connection Low Voltage (Required voltage is 24VDC±2V)
KEY CYLINDER NOT WORKING PROPERLY	Mechanical Interference Key Cylinder Engagement/Position in Lock
SECURE LOCK STATUS SIGNAL NOT GIVEN	Broken or Loose Wiring Faulty Status Switch Mechanical Deadlock Not Functioning Motor or Solenoid Positioned too Low Switch Arm adjustment
DOOR POSITION SIGNAL NOT GIVEN	Broken or Loose Wiring Door Adjustment Needed Magnetic Door Position Sensor adjustment needed