

AIRGLIDE 8220



U.S. PATENT NO. 5,070,575 AND 5,269,098

This maximum security locking device is designed with security foremost in mind. The door operator is contained in a securely baffled, continuous or individual, compact housing. Surface mounted locking column at rear of opening is of seamless, one piece construction to resist tampering. Provides for positive two point locking in both the open and closed position with automatic mechanical deadlock.

Doors may be individually unlocked, manually at the door, in the event of an emergency or power failure. The door travels on a solid 1" alloy steel track, using silent rollers with lifetime lubricated bearings to insure maximum reliability and quiet operation.

The **8220** is a pneumatically powered locking device designed for use in applications requiring remote unlocking and manual movement of sliding doors. The locking system provides smooth, quiet operation with minimal maintenance. Low power requirement (24 VDC) provides substantial cost savings in electrical power distribution and controls.

APPLICATION: Sliding door locking device for entrances, safety vestibules, corridors and cells.

DRIVE SYSTEM: Pneumatic

SECURITY LEVEL: ASTM F 1643 Grade 1

FIRE RATING: UL10B - 3 Hour

RELEASE SYSTEM: Remote controlled. Local manual in housing.

STANDARD FEATURES

- AirGlide door suspension system utilizes silent, lifetime lubricated patented rollers which travel on a 1" diameter alloy steel track.
- Door can be stopped or instantly reversed at any point in its travel without lost motion.
- Non-metallic door guide wear pads provide for smooth, silent operation.
- Side motion is limited to 1/16 inch or less, significantly reducing rattle induced noise.
- Closing force and speed of travel are independently adjustable for each door.
- Internal door position and lock status switches provide for deadlocked closed and deadlocked open indication.
- Fail-Secure (unlocks when energized)



2511 Midpark Rd., Montgomery, AL 36109

Phone: (800) 466-3007 Fax: (334) 286-6421

TECHNICAL SPECIFICATIONS

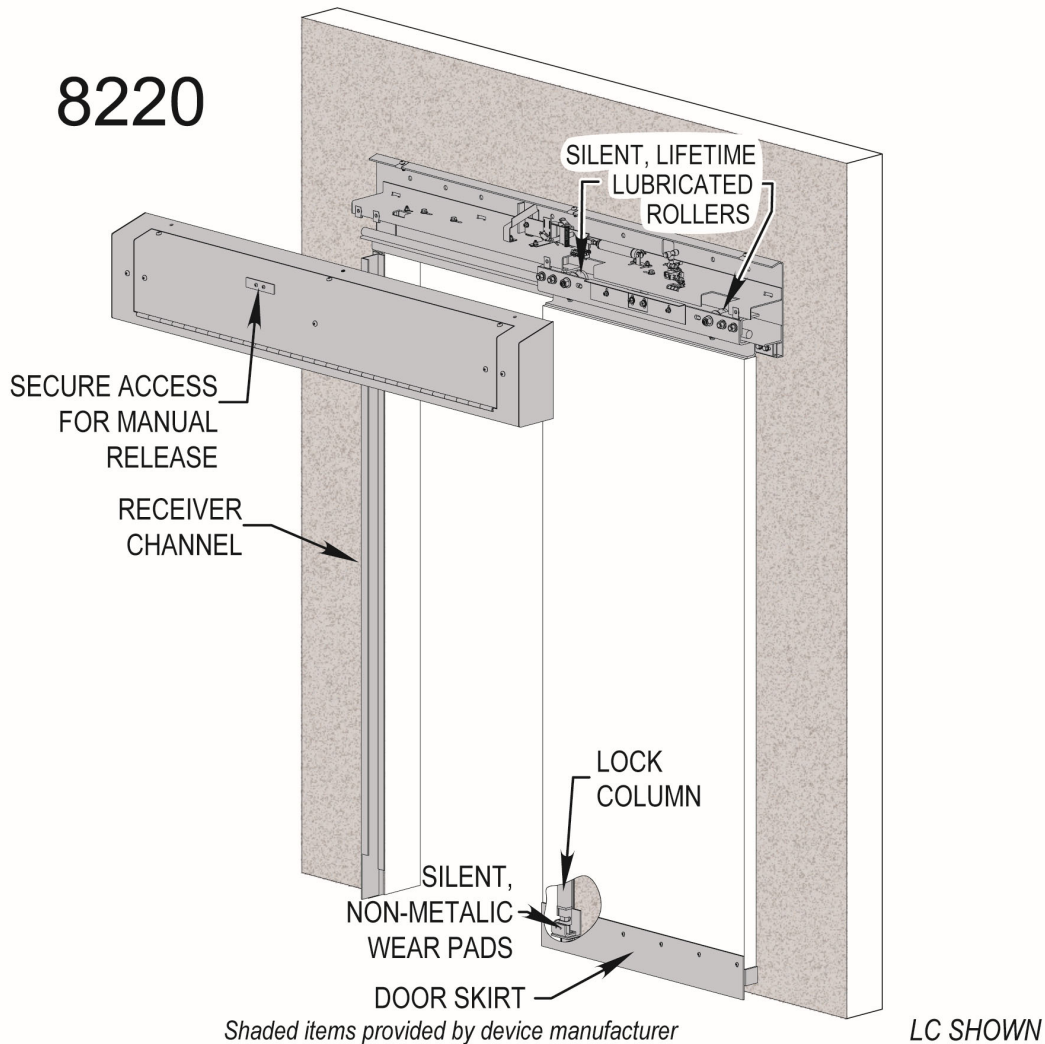

Specifications

- **Housing Cover:** 10 gauge steel, 6" deep x 12" high
- **Receiver Jamb:** 10 gauge steel channel
- **Lock Mechanism:** Two point rear locking column, surface mounted with automatic mechanical deadlock.
- **Manual Release Mechanism:** Security tool for release in housing cover
- **Indicator Switches:** 5 amps rated, UL recognized.
- **Solenoid:** 24 VDC continuous rated.
- **Electrical Power Requirements:** 7.2 watts max.
- **Air Consumption:** Unlock cycle uses 0.1 SCF for a typical 3 foot opening.
- **Air Tubing:** D.O.T. approved Nylon 11. Abrasion resistant thermoplastic tubing.
- **AirGlide Roller-Track Assembly:** Silent, lifetime lubricated, patented rollers travel on a 1" diameter alloy steel track.

Optional Features

- Secured access in housing cover is opened by paracentric key cylinder (Specify: PKA)
- Door is non-movable when stopped in mid-travel. (Specify: MTS)
- Door skirt to decrease standard 3 1/2" door undercut. (Specify: DS)
- Simple, inexpensive remote manual emergency release system. (Specify: RMERS)
- Fire Rated (specify FR)

Warranty

Airtec® warrants its products against defects in material or workmanship for one year from the time of delivery. Airtec's sole obligation under the warranty is to repair, or at its option, to replace the product. The buyer shall have no other remedy. (All special, incidental and coincidental damages are excluded.) Written notice of breach of warranty must be given to Airtec® within the warranty period. The warranty does not cover damages resulting from improper installation or maintenance, accident or misuse. NO OTHER WARRANTIES AS TO MERCHANTABILITY OR OTHERWISE ARE MADE. A continuing product re-