

AIRLOCK 9700



STANDARD OPERATION

- Latch bolt retracts when power is applied to the lock, when power is removed the latchbolt extends, locking the door if closed, or allowing the door to be slam-locked if open.
- Provides automatic deadlocking, even in the event of a total loss of air and/or power.
- Accepts a mogul key cylinder to allow for manual mechanical unlocking of the lock by key at the opening.
- Fail secure, unlocks when energized.



2511 Midpark Rd., Montgomery, AL 36109

Phone: (800) 466-3007 Fax: (334) 286-6421

The **9700** provides for pneumatic or manual locking / unlocking of swinging doors. It can be operated from a remote location or by key at the door. For additional security, it is recommended that the 9700 lock be used with an Airteq high security door position sensor. An automatic door closer may also be used.

APPLICATION:

Swing door lock for entrances, safety vestibules, corridors, inmate housing areas, and suitable for exterior locations. Gate mount Available.

SECURITY LEVEL:

ASTM F 1577 Grade 2, Grade 1 optional

KEY CYLINDER:

Mogul cylinder or builders key cylinder with mogul sleeve. (Sold Separately)

MOUNTING:

Jamb mounted in 7" frame, with either hinge side or stop side access cover.

FIRE RATING:

UL10B - 3 Hour

(not available with these functions: KLHB,ELHB,RLHB & RMERS)

STANDARD FEATURES

- Latch bolt has a full 1" throw
- Slam-locking with automatic mechanical deadlock
- Roller-type deadlock actuator
- Lock status switch indicates deadlocked latchbolt
- Keyed one or two sides
- Nickel plated Strike/Keeper furnished with tamper resistant screws
- Quick connect air and electrical connectors
- Factory wired field-side pigtail
- Bright zinc and stainless steel parts

TECHNICAL SPECIFICATIONS

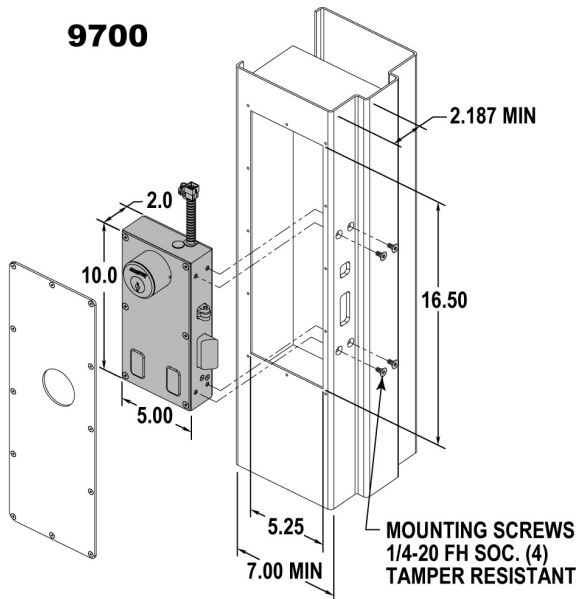

Shaded Items available from lock manufacturer **RHRB DOOR**

- **Body:** All steel construction
- **Dimensions:** 2" x 10" x 5"
- **Latchbolt:** 2" x 3/4" precision machined alloy steel, hardened to RC 60
- **Latchbolt Throw:** 1" - flush when retracted
- **Deadlock Actuator:** Roller type, stainless steel
- **Lock Status Switch:** 5 amp rated, UL recognized
- **Electrical Power Consumption:** 1.5 watt max (.063 amps)
- **Solenoid Valve:** 24 VDC continuous rated
- **Operating Range:** 24 VDC, ± 2 VDC
- **Air Consumption:** 2.5 cubic inches of air per actuation
- **Air Pressure Range:** 80 to 120 p.s.i.
- **Electrical Connector:** Quick connector with color coded wiring harness
- **Latchbolt Shear Strength:** 60,000 pounds
- **Strike/Keeper:** 1/2" hardened 1018 cold rolled steel, nickel plated with tamper resistant screws
- **UL10B:** 3 hour fire rating (see fire rating exceptions on cover page)
- **ASTM F 1577 Lock Function M200-P24**

HOW TO SPECIFY AND ORDER AN AIRTEQ 9700 LOCK

| WHEN SPECIFYING . . . | | | | | | | | | | ALSO SPECIFY . . . | | | | |
|---|---|--------------|---|------------------|---|-------------------|---|--------|---------------------------|-------------------------------|---|--------------------------|---|-----------|
| MODEL NO. | X | "K1" OR "K2" | X | FINISH | X | OPTIONAL FEATURES | | | -CYLINDER TYPE & MANUF'R. | | | | | |
| * WHEN ORDERING . . . | | | | | | | | | | -CYLINDER EXTENSION IF REQ'D. | | | | |
| MODEL NO. | X | SWING CODE | X | CYL. TYPE & MFR. | X | FRAME CONDITION | X | FINISH | X | OPTIONAL FEATURES | X | JAMB DEPTH (WHERE REQ'D) | X | DOOR THK. |
| EXAMPLE A: | | | | | | | | | | | | | | |
| WHEN SPECIFYING . . . | | | | | | | | | | | | | | |
| 9700 X K1 X US32D X AND SPECIFICATION READS. . . "MOGUL CYLINDERS, KEY SWITCH" | | | | | | | | | | | | | | |
| * WHEN ORDERING . . . | | | | | | | | | | | | | | |
| 9700 X 13 X AIRTEQ MOGUL X FR.POCKET X US32D X KS X 2"DR. | | | | | | | | | | | | | | |
| EXAMPLE B: | | | | | | | | | | | | | | |
| WHEN SPECIFYING . . . | | | | | | | | | | | | | | |
| 9700 X K2 X US32D X ELHB AND SPECIFICATION READS. . . "SECURITY BUILDERS CYLINDERS WITH CYLINDER EXTENSION REQUIRED." | | | | | | | | | | | | | | |
| * WHEN ORDERING . . . | | | | | | | | | | | | | | |
| 9700 X 08 X BLD.R.CYL X CYL.EXT. X US32D X ELHB X 9"JD X 2"DR. | | | | | | | | | | | | | | |
| * TEMPLATE NO. AND LATEST REVISIONS SHOULD BE COORDINATED WITH THE DOOR AND FRAME MANUFACTURER. | | | | | | | | | | | | | | |

SWING/HAND CHART

| SWING CODE | DOOR HAND DIAGRAM *COVER PLATE | SWING CODE | DOOR HAND DIAGRAM *COVER PLATE |
|------------|--------------------------------|------------|--------------------------------|
| 07 LHRB | | 08 RHRB | |
| 09 RH | | 10 LH | |
| 11 LHRB | | 12 RHRB | |
| 13 RH | | 14 LH | |

Optional Features

- ◆ **RMERS** - Remote Manual Emergency Release System: Latchbolt is retracted remotely by a manually operated valve in the event of a loss of normal control functions. Requires an additional air line to the lock and a separate emergency air system cabinet (sold separately). Fire rating not available with this feature.
- ◆ **ARB** - (Adjustable Roller Bolt): Allows for adjustment of the roller type deadlock actuator when the standard strike/keeper is not used.
- ◆ **KR** - Knob Release: Latchbolt is retracted by knob release on one side of lock. Knob is always active. When ordering, specify hinge side (HS) or stop side (SS).
- ◆ **GR1** - ASTM Grade 1 Rating: Meets ASTM F1577 Grade 1 impact standards
- ◆ **KCE** - Key Cylinder Extension: Recommended for locks keyed stop side or keyed two sides.

Optional Functions

- ◆ **RLHB** - Remote Latch Holdback: Latch bolt is retracted by push button at the control panel and remains retracted until button is pushed a second time (control feature). Fire rating not available with this function.
- ◆ **KS** - Key Switch: Door is electrically unlocked by key operated switch at the lock. Can be disabled by the control system.
- ◆ **LEK** - Local Electric Key Switch: Provides for one key which operates lock electrically only, while higher level keys will operate it both mechanically and electrically. Includes 'KS' function plus a special function key cylinder.
- ◆ **KLHB** - Key operated Latch HoldBack: Latch is retracted locally by key and remains mechanically retracted until relocked by key. Fire rating not available with this function.
- ◆ **ELHB** - Emergency Latch HoldBack: Latchbolt is retracted remotely and remains mechanically retracted until relocked at the door by key (includes KLHB feature). Fire rating not available with this function.
- ◆ **RLB** - Remote Latch Back: Latchbolt is retracted remotely and remains retracted until door is opened approximately 2". Door relocks when closed.

NOTE: PLEASE CONTACT AIRTEQ WHEN MORE THAN ONE FUNCTION IS REQUIRED ON THE SAME LOCK.

Warranty

Airteq® warrants its products against defects in material or workmanship for one year from the time of delivery. Airteq's sole obligation under the warranty is to repair, or at its option, to replace the product. The buyer shall have no other remedy. (All special, incidental and coincidental damages are excluded.) Written notice of breach of warranty must be given to Airteq® within the warranty period. The warranty does not cover damages resulting from improper installation or maintenance, accident or misuse. NO OTHER WARRANTIES AS TO MERCHANTABILITY OR OTHERWISE ARE MADE. A continuing product research program is ongoing. Airteq® reserves the right to incorporate products and specification changes at any time without notice.