

MOTORGLIDE 7210



U.S. PATENT NO. 5,070,575

The 7210 is an electrically powered locking device designed for use in applications requiring remote electrical unlocking and manual movement of sliding doors. This motorized locking system provides smooth, quiet operation with minimal maintenance. Low power requirement (24 VDC) provides substantial cost savings in electrical power distribution and controls.

This maximum security locking device is designed with security foremost in mind. The door operator is contained in a securely baffled, continuous or individual, compact housing. Surface mounted locking column at rear of opening is of seamless, one piece construction to resist tampering. Provides for positive 2-point locking in both the open and closed position with automatic mechanical deadlock.



2511 Mid Park Road
Montgomery, AL 36109
Phone: (800) 466-3007 Fax: (334)286-6421

Doors may be individually unlocked manually at the door in the event of an emergency or power failure. The door travels on a solid alloy steel track, using silent non-metallic rollers with lifetime lubricated bearings to insure maximum reliability and quiet operation.

APPLICATION: Sliding door locking device for cells

DRIVE SYSTEM: Manual with automatic 3" door movement at unlock

RELEASE SYSTEM: Remote electric. Local manual in housing

STANDARD FEATURES

- The door electrically unlocks and moves approximately 3 inches from either the locked closed or locked open position
- MotorGlide door suspension system utilizes silent, lifetime lubricated patented rollers which travel on a 1" diameter alloy steel track
- Non-metallic door guide wear pads provide for smooth, silent operation
- Side motion is limited to 1/16 inch or less, significantly reducing rattle induced noise
- Each door may be unlocked manually by inserting a tool through a secured access in the housing cover
- Door may be manually unlocked and slam-locked with automatic mechanical deadlocking
- Internal door position and lock status switches provide for deadlocked closed and deadlocked open indication
- Fail-secure (unlocks when energized)

OPTIONAL FEATURES

- Secured access in housing cover is opened
- Door skirt to decrease standard 3 1/2" door undercut (specify DS)
- Hinged housing cover (specify HHC)
- Fire Rated (specify FR)

TECHNICAL SPECIFICATIONS

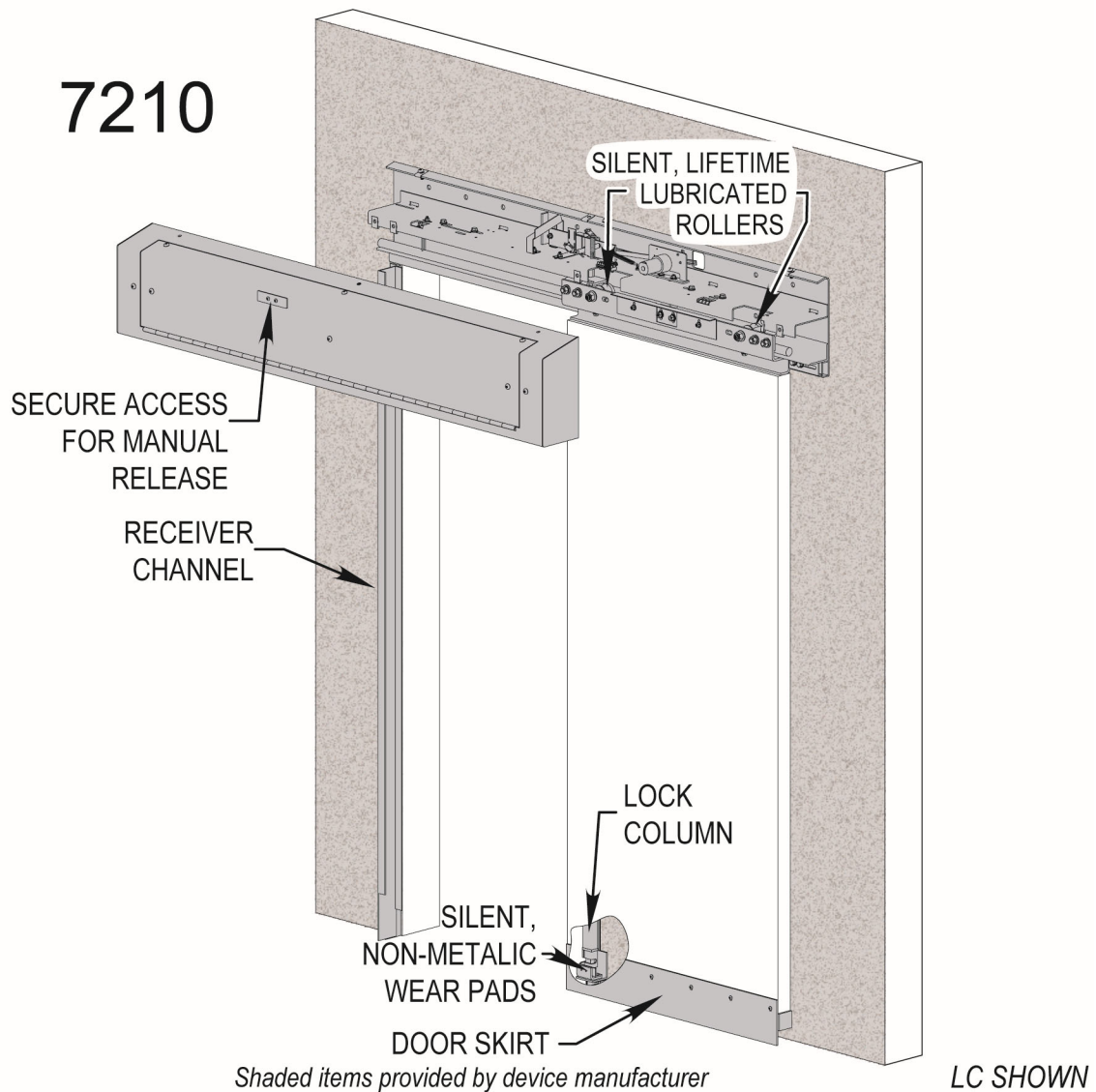

Specifications

- **Housing Cover:** 10 gauge steel, 6" deep x 12" high
- **Receiver Jamb:** 10 gauge steel channel
- **Lock Mechanism:** Two-point rear locking column, surface mounted with automatic mechanical deadlock
- **Fail Secure:** Unlocks when energized
- **Release Mechanism:** Security tool for release in housing cover
- **Indicator Switches:** 5 amps rated, UL recognized
- **Motor:** 24 VDC continuous rated
- **Electrical Power Requirements:** 0.5 amps running, 1.9 amps stalled
- **Drive Mechanism:** Manual
- **MotorGlide Roller-Track Assembly:** Silent, lifetime lubricated, patented rollers travel on a 1" diameter alloy steel track

Warranty

Airteq warrants its products against defects in material or workmanship for one year from the time of delivery. Airteq's sole obligation under the warranty is to repair, or at its option, to replace the product. The buyer shall have no other remedy. (All special, incidental and coincidental damages are excluded.) Written notice of breach of warranty must be given to Airteq within the warranty period. The warranty does not cover damages resulting from improper installation or maintenance, accident or misuse. NO OTHER WARRANTIES AS TO MERCHANTABILITY OR OTHERWISE ARE MADE. A continuing product research program is ongoing. Airteq reserves the right to incorporate products and specification changes at any time without notice.