

# MOTORLOCK 9724



The **9724** provides for electric or manual locking / unlocking of swinging doors. It can be operated from a remote location or by key at the door. For additional security, it is recommended that the 9724 lock be used with an Airteq high security door position sensor. An automatic door closer may also be used.

## APPLICATION:

Swing door lock for entrances, safety vestibules, corridors, inmate housing, and suitable for exterior locations.

## SECURITY LEVEL:

ASTM F 1577 Grade 2, Grade 1 optional

## KEY CYLINDER:

Mogul cylinder or builders key cylinder with mogul sleeve (sold separately).

## MOUNTING:

Jamb mounted in 7" frame with either hinge side or stop side access cover.

## FIRE RATING:

UL10B - 3 Hour

(not available with these functions: KLHB,ELHB & RLHB)

## STANDARD OPERATION

- Latch bolt retracts when momentary signal is applied to the lock and remains retracted for a specified interval, at which time the latchbolt extends, locking the door if closed, or allowing the door to be slam-locked if open.
- Provides automatic deadlocking, even in the event of a total loss of power.
- Accepts a mogul key cylinder to allow for manual mechanical unlocking of the lock by key at the opening.
- Fail secure, unlocks when energized.

## STANDARD FEATURES

- Latch bolt has a full 1" throw
- Slam-locking with automatic mechanical deadlock
- Roller-type deadlock actuator
- Lock status switch indicates deadlocked latchbolt
- Keyed one or two sides
- Plated Strike/Keeper furnished with tamper resistant screws
- Quick connect electrical connectors
- Factory wired field-side pigtail
- Plated and stainless steel parts



# TECHNICAL SPECIFICATIONS

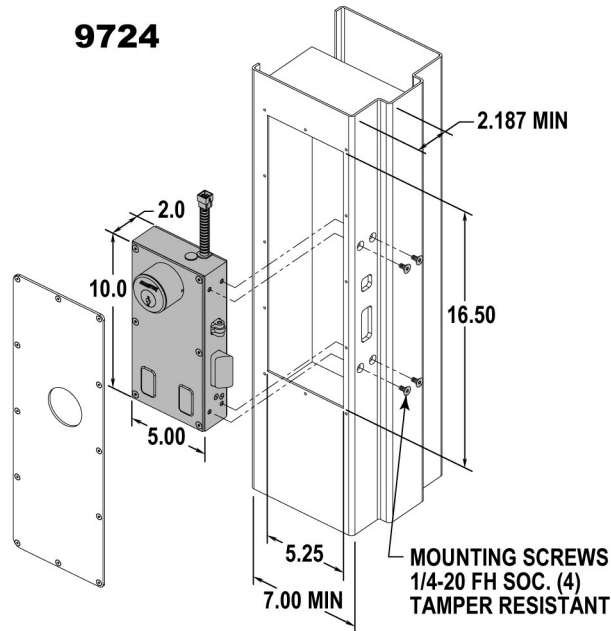

Shaded Items available from lock manufacturer **RHRB DOOR**

- **Body:** All steel construction
- **Dimensions:** 2" x 10" x 5"
- **Latchbolt:** 2" x 3/4" precision machined alloy steel, hardened to RC 60
- **Latchbolt Throw:** 1" - Flush when retracted
- **Deadlock Actuator:** Roller type, stainless steel
- **Lock Status Switch:** 5 amp rated, UL recognized
- **Electrical Power Consumption:** 36 watt max. at 24 VDC, 1.5 amps
- **Motor:** 2 phase, bi-polar, brushless linear actuator
- **Operating Range:** 24 VDC ± 2VDC
- **Electrical Connector:** Quick connector with color coded wiring harness
- **Latchbolt Shear Strength:** 60,000 pounds
- **Strike/Keeper:** 1/2" hardened 1018 cold rolled steel, nickel plated with tamper resistant screws
- **UL10B:** 3 hour fire rating (see fire rating exceptions on cover page)
- **ASTM F 1577 Lock Function C200-P24**

## HOW TO SPECIFY AND ORDER AN AIRTEQ 9724 LOCK

WHEN SPECIFYING . . .						ALSO SPECIFY . . .								
MODEL NO.	X	"K1" OR "K2"	X	FINISH	X	OPTIONAL FEATURES	-CYLINDER TYPE & MANUF'R. -CYLINDER EXTENSION IF REQ'D.							
* WHEN ORDERING . . .														
MODEL NO.	X	SWING CODE	X	CYL. TYPE & MFR.	X	FRAME CONDITION	X	FINISH	X	OPTIONAL FEATURES	X	JAMB DEPTH (WHERE REQ'D)	X	DOOR THK.
<b>EXAMPLE A:</b> WHEN SPECIFYING . . . 9724 X K1 X US32D <b>AND SPECIFICATION READS . . . "MOGUL CYLINDERS, KEY SWITCH"</b> * WHEN ORDERING . . . 9724 X 13 X AIRTEQ MOGUL X FR. POCKET X US32D X KS X 2"DR.														
<b>EXAMPLE B:</b> WHEN SPECIFYING . . . 9724 X K2 X US32D X RLHB <b>AND SPECIFICATION READS . . . "SECURITY BUILDERS CYLINDERS WITH CYLINDER EXTENSION REQUIRED."</b> * WHEN ORDERING . . . 9724 X 08 X BLDR.CYL X CYL.EXT. X US32D X RLHB X 9"JD X 2"DR.														
* TEMPLATE NO. AND LATEST REVISIONS SHOULD BE COORDINATED WITH THE DOOR AND FRAME MANUFACTURER.														

## SWING/HAND CHART

SWING CODE	DOOR HAND DIAGRAM *COVER PLATE	SWING CODE	DOOR HAND DIAGRAM *COVER PLATE
07 LHRB		08 RHRB	
09 RH		10 LH	
11 LHRB		12 RHRB	
13 RH		14 LH	

### Optional Features

- ◆ **KR** - Knob Release: Latchbolt is retracted by knob release on one side of lock. Knob is always active. When ordering, specify hinge side (HS) or stop side (SS).
- ◆ **GR1** - ASTM Grade 1 Rating: Meets ASTM F1577 Grade 1 impact standards
- ◆ **KCE** - Key Cylinder Extension: Recommended for locks keyed stop side or keyed two sides.
- ◆ **ARB** - Adjustable Roller Bolt: Allows for adjustment of the roller bolt deadlock actuator when the standard strike/keeper is not used.

### Optional Functions

- ◆ **RLHB** - Remote Latch Holdback: Latch bolt is retracted by push button at the control panel and remains retracted until button is pushed a second time (control feature).
- ◆ **KS** - Key Switch: Door is electrically unlocked by key operated switch at the lock. Can be disabled by the control system.
- ◆ **LEK** - Local Electric Key Switch: Provides for one key which operates lock electrically only, while higher level keys will operate it both mechanically and electrically. Includes 'KS' function plus a special function key cylinder.
- ◆ **KLHB** - Key operated Latch HoldBack: Latch is retracted locally by key and remains mechanically retracted until relocked by key.
- ◆ **ELHB** - Emergency Latch HoldBack: Latchbolt is retracted remotely and remains mechanically retracted until relocked at the door by key (includes KLHB feature).
- ◆ **RLB** - Remote Latch Back: Latchbolt is retracted remotely and remains retracted until door is opened approximately 2". Door relocks when closed.

**NOTE: PLEASE CONTACT AIRTEQ WHEN MORE THAN ONE FUNCTION IS REQUIRED ON THE SAME LOCK.**

### Warranty

Airteq warrants its products against defects in material or workmanship for one year from the time of delivery. Airteq's sole obligation under the warranty is to repair, or at its option, to replace the product. The buyer shall have no other remedy. (All special, incidental and coincidental damages are excluded.) Written notice of breach of warranty must be given to Airteq within the warranty period. The warranty does not cover damages resulting from improper installation or maintenance, accident or misuse. NO OTHER WARRANTIES AS TO MERCHANTABILITY OR OTHERWISE ARE MADE. A continuing product research program is ongoing. Airteq reserves the right to incorporate products and specification changes at any time without notice.